



Cisco ASR 9000 Series Aggregation Services Router Getting Started Guide

Cisco IOS XR Software Release 3.7.2
March, 2009

Americas Headquarters
Cisco Systems, Inc.
170 West Tasman Drive
San Jose, CA 95134-1706
USA
<http://www.cisco.com>
Tel: 408 526-4000
800 553-NETS (6387)
Fax: 408 527-0883

Text Part Number: OL-17502-01

THE SPECIFICATIONS AND INFORMATION REGARDING THE PRODUCTS IN THIS MANUAL ARE SUBJECT TO CHANGE WITHOUT NOTICE. ALL STATEMENTS, INFORMATION, AND RECOMMENDATIONS IN THIS MANUAL ARE BELIEVED TO BE ACCURATE BUT ARE PRESENTED WITHOUT WARRANTY OF ANY KIND, EXPRESS OR IMPLIED. USERS MUST TAKE FULL RESPONSIBILITY FOR THEIR APPLICATION OF ANY PRODUCTS.

THE SOFTWARE LICENSE AND LIMITED WARRANTY FOR THE ACCOMPANYING PRODUCT ARE SET FORTH IN THE INFORMATION PACKET THAT SHIPPED WITH THE PRODUCT AND ARE INCORPORATED HEREIN BY THIS REFERENCE. IF YOU ARE UNABLE TO LOCATE THE SOFTWARE LICENSE OR LIMITED WARRANTY, CONTACT YOUR CISCO REPRESENTATIVE FOR A COPY.

The Cisco implementation of TCP header compression is an adaptation of a program developed by the University of California, Berkeley (UCB) as part of UCB's public domain version of the UNIX operating system. All rights reserved. Copyright © 1981, Regents of the University of California.

NOTWITHSTANDING ANY OTHER WARRANTY HEREIN, ALL DOCUMENT FILES AND SOFTWARE OF THESE SUPPLIERS ARE PROVIDED "AS IS" WITH ALL FAULTS. CISCO AND THE ABOVE-NAMED SUPPLIERS DISCLAIM ALL WARRANTIES, EXPRESSED OR IMPLIED, INCLUDING, WITHOUT LIMITATION, THOSE OF MERCHANTABILITY, FITNESS FOR A PARTICULAR PURPOSE AND NONINFRINGEMENT OR ARISING FROM A COURSE OF DEALING, USAGE, OR TRADE PRACTICE.

IN NO EVENT SHALL CISCO OR ITS SUPPLIERS BE LIABLE FOR ANY INDIRECT, SPECIAL, CONSEQUENTIAL, OR INCIDENTAL DAMAGES, INCLUDING, WITHOUT LIMITATION, LOST PROFITS OR LOSS OR DAMAGE TO DATA ARISING OUT OF THE USE OR INABILITY TO USE THIS MANUAL, EVEN IF CISCO OR ITS SUPPLIERS HAVE BEEN ADVISED OF THE POSSIBILITY OF SUCH DAMAGES.

CCDE, CCSI, CCENT, Cisco Eos, Cisco HealthPresence, the Cisco logo, Cisco Lumin, Cisco Nexus, Cisco Nurse Connect, Cisco Stackpower, Cisco StadiumVision, Cisco TelePresence, Cisco WebEx, DCE, and Welcome to the Human Network are trademarks; Changing the Way We Work, Live, Play, and Learn and Cisco Store are service marks; and Access Registrar, Aironet, AsyncOS, Bringing the Meeting To You, Catalyst, CCDA, CCDP, CCIE, CCIP, CCNA, CCNP, CCSP, CCVP, Cisco, the Cisco Certified Internetwork Expert logo, Cisco IOS, Cisco Press, Cisco Systems, Cisco Systems Capital, the Cisco Systems logo, Cisco Unity, Collaboration Without Limitation, EtherFast, EtherSwitch, Event Center, Fast Step, Follow Me Browsing, FormShare, GigaDrive, HomeLink, Internet Quotient, IOS, iPhone, iQuick Study, IronPort, the IronPort logo, LightStream, Linksys, MediaTone, MeetingPlace, MeetingPlace Chime Sound, MGX, Networkers, Networking Academy, Network Registrar, PCNow, PIX, PowerPanels, ProConnect, ScriptShare, SenderBase, SMARTnet, Spectrum Expert, StackWise, The Fastest Way to Increase Your Internet Quotient, TransPath, WebEx, and the WebEx logo are registered trademarks of Cisco Systems, Inc. and/or its affiliates in the United States and certain other countries.

All other trademarks mentioned in this document or website are the property of their respective owners. The use of the word partner does not imply a partnership relationship between Cisco and any other company. (0903R)

Any Internet Protocol (IP) addresses used in this document are not intended to be actual addresses. Any examples, command display output, and figures included in the document are shown for illustrative purposes only. Any use of actual IP addresses in illustrative content is unintentional and coincidental.

Cisco ASR 9000 Series Aggregation Services Router Getting Started Guide
© 2009 Cisco Systems, Inc. All rights reserved.



CONTENTS

Preface xi

Changes to This Document	xi
About This Document	xi
Intended Audience	xii
Organization of the Document	xii
Conventions	xii
Obtaining Documentation and Submitting a Service Request	xiii

Introducing the Cisco ASR 9000 Series Aggregation Services Router 1-1

Contents	1-1
Router Overview	1-1
Features and Capabilities	1-1
Cisco IOS XR Software	1-2
Flexible Ethernet	1-3
L2VPN	1-4
Multicast	1-4
OAM	1-4
Layer 3 routing	1-5
MPLS VPN	1-5
QoS	1-5
MPLS TE	1-5
High Availability	1-6
System Configurations	1-6
Management and Security	1-8
Manageability	1-8
Security	1-9
Initial Router Configuration	1-9
Management Interfaces	1-9
Command-Line Interface	1-10
Extensible Markup Language API	1-10
Simple Network Management Protocol	1-10
Connecting to the Router Through the Console Port	1-11
Configuring Gigabit Ethernet and 10-Gigabit Ethernet Interfaces	1-13
Where to Go Next	1-13

Bringing Up Cisco IOS XR Software on the Router	2-1
Contents	2-1
Prerequisites	2-1
Software Requirements	2-2
Hardware Prerequisites and Documentation	2-2
Bringing Up and Configuring the Router	2-2
Examples	2-3
Verifying the System After Initial Boot	2-4
Examples of show Commands	2-5
Where to Go Next	2-8
Configuring General Router Features	3-1
Contents	3-1
Connecting to and Communicating with the Router	3-1
Connecting Through the Console Port	3-2
Connecting Through a Terminal Server	3-3
Connecting Through the Management Ethernet Interface	3-5
Logging In to a Router	3-5
CLI Prompt	3-6
User Access Privileges	3-7
User Groups, Task Groups, and Task IDs	3-7
Predefined User Groups	3-8
Viewing Your User Groups and Task IDs	3-8
Examples	3-8
Navigating Cisco IOS XR Software Command Modes	3-10
Identifying the Command Mode in the CLI Prompt	3-11
Common Command Modes	3-12
Entering EXEC Commands from a Configuration Mode	3-14
Command Mode Navigation Example	3-15
Managing Configuration Sessions	3-16
Entering Configuration Changes	3-17
Viewing Active Configuration Sessions	3-19
Starting a Configuration Session	3-20
Examples	3-20
Starting an Exclusive Configuration Session	3-21
Viewing Configuration Details	3-21
Viewing the Running Configuration	3-21
Viewing a Sanitized Version of the Running Configuration	3-22
Viewing the Target Configuration	3-23

Viewing a Combined Target and Running Configuration	3-24
Viewing Configuration Error Messages and Descriptions	3-25
Viewing Configuration Error Messages Without Descriptions	3-25
Viewing Configuration Error Messages Produced While Loading a Configuration	3-25
Saving the Target Configuration to a File	3-26
Loading the Target Configuration from a File	3-26
Loading an Alternative Configuration at System Startup	3-26
Clearing All Changes to a Target Configuration	3-27
Committing Changes to the Running Configuration	3-27
Examples	3-29
Reloading a Failed Configuration	3-29
Exiting a Configuration Submode	3-30
Returning Directly to Configuration Mode from a Submode	3-30
Ending a Configuration Session	3-31
Aborting a Configuration Session	3-31
Configuring the RSP Hostname	3-31
Configuring the Management Ethernet Interface	3-32
Specifying the Management Ethernet Interface Name in CLI Commands	3-32
Viewing the Available Management Ethernet Interfaces	3-33
Configuring the Management Ethernet Interface	3-33
Prerequisites	3-34
Examples	3-36
Related Documents	3-36
Manually Setting the Router Clock	3-36
Examples	3-38
Related Documents	3-38
Where to Go Next	3-38

Configuring Additional Router Features 4-1

Contents	4-1
Configuring the Domain Name and Domain Name Server	4-1
Examples	4-3
Configuring Telnet and XML Host Services	4-3
Prerequisites	4-4
Examples	4-5
Managing Configuration History and Rollback	4-6
Viewing CommitIDs	4-7
Viewing Configuration Changes Recorded in a CommitID	4-7
Previewing Rollback Configuration Changes	4-8

Rolling Back the Configuration to a Specific Rollback Point	4-8
Rolling Back the Configuration over a Specified Number of Commits	4-9
Loading CommitID Configuration Changes to the Target Configuration	4-9
Loading Rollback Configuration Changes to the Target Configuration	4-10
Deleting CommitIDs	4-11
Configuring Logging and Logging Correlation	4-12
Logging Locations and Severity Levels	4-12
Alarm Logging Correlation	4-13
Configuring Basic Message Logging	4-13
Examples	4-14
Related Documents	4-15
Disabling Console Logging	4-15
Creating and Modifying User Accounts and User Groups	4-15
Viewing Details About User Accounts, User Groups, and Task IDs	4-16
Configuring User Accounts	4-17
Creating Users and Assigning Groups	4-17
Related Documents	4-18
Configuring Software Entitlement	4-19
Configuration Limiting	4-19
Static Route Configuration Limits	4-20
Examples	4-20
IS-IS Configuration Limits	4-20
Examples	4-21
OSPFv2 and v3 Configuration Limits	4-21
Examples	4-21
Routing Policy Language Line and Policy Limits	4-23
Examples	4-24
Multicast Configuration Limits	4-25
MPLS Configuration Limits	4-26
Other Configuration Limits	4-26
CLI Tips, Techniques, and Shortcuts	5-1
Contents	5-1
CLI Tips and Shortcuts	5-1
Entering Abbreviated Commands	5-1
Using the Question Mark (?) to Display On-Screen Command Help	5-2
Completing a Partial Command with the Tab Key	5-4
Identifying Command Syntax Errors	5-4
Using the no Form of a Command	5-4

Editing Command Lines that Wrap	5-5
Viewing System Information with show Commands	5-5
Common show Commands	5-6
Browsing Display Output when the --More-- Prompt Appears	5-6
Halting the Display of Screen Output	5-7
Redirecting Output to a File	5-7
Narrowing Output from Large Configurations	5-8
Limiting show Command Output to a Specific Feature or Interface	5-8
Using Wildcards to Display All Instances of an Interface	5-8
Filtering show Command Output	5-9
Adding a Filter at the --More-- Prompt	5-10
Multipipe Support	5-11
Show Parser Dump Enhancement Feature	5-11
Wildcards, Templates, and Aliases	5-12
Using Wildcards to Identify Interfaces in show Commands	5-12
Example	5-12
Creating Configuration Templates	5-13
Examples	5-15
Applying Configuration Templates	5-15
Examples	5-15
Aliases	5-16
Keystrokes Used as Command Aliases	5-17
Command History	5-17
Viewing Previously Entered Commands	5-17
Recalling Previously Entered Commands	5-17
Recalling Deleted Entries	5-18
Redisplaying the Command Line	5-18
Key Combinations	5-18
Key Combinations to Move the Cursor	5-19
Keystrokes to Control Capitalization	5-19
Keystrokes to Delete CLI Entries	5-20
Transposing Mistyped Characters	5-20
Troubleshooting the Cisco IOS XR Software	6-1
Contents	6-1
Additional Sources for Information	6-1
Basic Troubleshooting Commands	6-2
Using show Commands to Display System Status and Configuration	6-2
Using the ping Command	6-2

- Examples 6-2
- Using the traceroute Command 6-3
 - Examples 6-3
- Using debug Commands 6-3
 - Viewing a List of Debug Features 6-4
 - Enabling Debugging for a Feature 6-5
 - Viewing Debugging Status 6-5
 - Disabling Debugging for a Service 6-5
 - Disabling Debugging for All Services Started at the Active Terminal Session 6-6
 - Disabling Debugging for All Services Started at All Terminal Sessions 6-6
- Configuration Error Messages 6-6
 - Configuration Failures During a Commit Operation 6-6
 - !Configuration Errors at Startup 6-7
- Memory Warnings in Configuration Sessions 6-7
 - Understanding Low-Memory Warnings in Configuration Sessions 6-8
 - “WARNING! MEMORY IS IN MINOR STATE” 6-8
 - “ERROR! MEMORY IS IN SEVERE (or CRITICAL) STATE” 6-8
 - Viewing System Memory Information 6-9
 - Removing Configurations to Resolve Low-Memory Warnings 6-10
 - Clearing a Target Configuration 6-10
 - Removing Committed Configurations to Free System Memory 6-10
 - Rolling Back to a Previously Committed Configuration 6-11
 - Clearing Configuration Sessions 6-11
 - Contacting TAC for Additional Assistance 6-11
- Interfaces Not Coming Up 6-12
 - Verifying System Interfaces 6-12

APPENDIX A

Understanding Regular Expressions, Special Characters, and Patterns A-1

- Contents A-1
- Regular Expressions A-1
- Special Characters A-2
- Character Pattern Ranges A-2
- Multiple-Character Patterns A-3
- Complex Regular Expressions Using Multipliers A-3
- Pattern Alternation A-4
- Anchor Characters A-4
- Underscore Wildcard A-4
- Parentheses Used for Pattern Recall A-4



Preface

This guide introduces the Cisco ASR 9000 Series Aggregation Services Router that runs Cisco IOS XR Software. This guide also describes administration, maintenance, and troubleshooting tasks that may be required after initially starting the router.

This preface contains the following sections:

- [Changes to This Document, page xi](#)
- [About This Document, page xi](#)
- [Obtaining Documentation and Submitting a Service Request, page xiii](#)

Changes to This Document

[Table 1](#) lists technical changes made to this document since it was first released.

Table 1 **Changes to This Document**

Revision	Date	Change Summary
OL-17502-01	March, 2009	Initial release of this document.

About This Document

The following sections provide information about *Cisco ASR 9000 Series Aggregation Services Router Getting Started Guide* and related documents:

- [Intended Audience, page xii](#)
- [Organization of the Document, page xii](#)
- [Conventions, page xii](#)

Intended Audience

This document is intended for the following people:

- Experienced service provider administrators
- Cisco telecommunications management engineers
- Third-party field service technicians who have completed the Cisco IOS XR Software training sessions
- Customers who use and manage routers running Cisco IOS XR Software

Organization of the Document

This document contains the following chapters:

- [Chapter 1, “Introducing the Cisco ASR 9000 Series Aggregation Services Router”](#)
- [Chapter 2, “Bringing Up Cisco IOS XR Software on the Router”](#)
- [Chapter 3, “Configuring General Router Features”](#)
- [Chapter 4, “Configuring Additional Router Features”](#)
- [Chapter 5, “CLI Tips, Techniques, and Shortcuts”](#)
- [Chapter 6, “Troubleshooting the Cisco IOS XR Software”](#)
- [Appendix A, “Understanding Regular Expressions, Special Characters, and Patterns,”](#)

Conventions

This document uses the following conventions:

Item	Convention
Commands and keywords	boldface font
Variable for which you supply values	<i>italic</i> font
Displayed session and system information	<code>screen</code> font
Commands and keywords you enter in an interactive environment	boldface screen font
Variables you enter in an interactive environment	<i>italic screen</i> font
Menu items and button names	boldface font
Menu navigation	Option > Network Preferences



Note

Means *reader take note*. Notes contain helpful suggestions or references to material not covered in the publication.

**Tip**

Means *the following information will help you solve a problem*. The information in tips might not be troubleshooting or an action, but contains useful information.

**Caution**

Means *reader be careful*. In this situation, you might do something that could result in equipment damage or loss of data.

Obtaining Documentation and Submitting a Service Request

For information on obtaining documentation, submitting a service request, and gathering additional information, see the monthly *What's New in Cisco Product Documentation*, which also lists all new and revised Cisco technical documentation, at:

<http://www.cisco.com/en/US/docs/general/whatsnew/whatsnew.html>

Subscribe to the *What's New in Cisco Product Documentation* as a Really Simple Syndication (RSS) feed and set content to be delivered directly to your desktop using a reader application. The RSS feeds are a free service, and Cisco currently supports RSS version 2.0.



CHAPTER 1

Introducing the Cisco ASR 9000 Series Aggregation Services Router

This chapter introduces the Cisco ASR 9000 Series router that runs Cisco IOS XR Software. It also introduces router concepts, features, and user interfaces.

Contents

- [Router Overview, page 1-1](#)
- [System Configurations, page 1-6](#)
- [Management and Security, page 1-8](#)
- [Initial Router Configuration, page 1-9](#)
- [Where to Go Next, page 1-13](#)

Router Overview

The Cisco ASR 9000 Series router is a multilayer Ethernet switching and aggregation platform. It is also a label edge router (LER) that sits at the edge of a Multiprotocol Label Switching (MPLS) network. The router has links that extend outside the MPLS network. It provides access and aggregation services for enterprise and service providers.

Features and Capabilities

A scalable, carrier-class distributed forwarding router, the router is designed for the redundancy, high security and availability, packaging, power and other requirements needed by service providers.

The router aggregates triple play and Ethernet service traffic from Gigabit Ethernet devices, aggregating these services to 10 Gigabit Ethernet IP, MPLS edge, or core.

The following sections describe the features and capabilities in detail:

- [Cisco IOS XR Software, page 1-2](#)
- [Flexible Ethernet, page 1-3](#)
- [L2VPN, page 1-4](#)

- [Multicast, page 1-4](#)
- [OAM, page 1-4](#)
- [Layer 3 routing, page 1-5](#)
- [QoS, page 1-5](#)
- [MPLS TE, page 1-5](#)
- [Manageability, page 1-8](#)
- [Security, page 1-9](#)
- [Command-Line Interface, page 1-10](#)
- [Extensible Markup Language API, page 1-10](#)
- [Simple Network Management Protocol, page 1-10](#)

Cisco IOS XR Software

The Cisco ASR 9000 Series router runs Cisco IOS XR Software, this offers the following:

- **Modular software design:** Cisco IOS XR Software represents a continuation of the Cisco networking leadership in helping customers realize the power of their networks and the Internet. It provides unprecedented routing-system scalability, high availability, service isolation, and manageability to meet the mission-critical requirements of next-generation networks.
- **Operating system infrastructure protection:** Cisco IOS XR Software provides a microkernel architecture that forces all but the most critical functions, such as memory management and thread distribution, outside of the kernel, thereby preventing failures in applications, file systems, and even device drivers from causing widespread service disruption.
- **Process and thread protection:** Each process—even individual process threads—is executed in its own protected memory space, and communications between processes are accomplished through well-defined, secure, and version-controlled application programming interfaces (APIs), significantly minimizing the effect that any process failure can have on other processes.
- **Cisco In-Service Software Upgrade (ISSU):** Cisco IOS XR Software modularity sustains system availability during installation of a software upgrade. ISSUs or hitless software upgrades (HSUs) allow you to upgrade most Cisco router software features without affecting deployed services. You can target particular system components for upgrades based on software packages or composites that group selected features. Cisco preconfigures and tests these packages and composites to help ensure system compatibility.
- **Process restart:** You can restart critical control-plane processes both manually and automatically in response to a process failure versus restarting the entire operating system. This feature supports the Cisco IOS XR Software goal of continuous system availability and allows for quick recovery from process or protocol failures with minimal disruption to customers or traffic.
- **State checkpointing:** You can maintain a memory and critical operating state across process restarts in order to sustain routing adjacencies and signaling state during a route-switch-processor (RSP) switchover.
- **Ethernet virtual connections (EVCs):** Ethernet services are supported using individual EVCs to carry traffic belonging to a specific service type or end user through the network. You can use EVC-based services in conjunction with MPLS-based L2VPNs and native IEEE bridging deployments.

- Flexible VLAN classification: VLAN classification into Ethernet flow points (EFPs) includes single-tagged VLANs, double-tagged VLANs (QinQ and IEEE 802.1ad), contiguous VLAN ranges, and noncontiguous VLAN lists.
- IEEE Bridging: The software supports native bridging based on IEEE 802.1Q, IEEE 802.1ad, and QinQ VLAN encapsulation mechanisms on the router.
- IEEE 802.1s Multiple Spanning Tree (MST): MST extends the IEEE 802.1w Rapid Spanning Tree Protocol (MSTP) to multiple spanning trees, providing rapid convergence and load balancing.
- MST Access Gateway: This feature provides a resilient, fast-convergence mechanism for aggregating and connecting to Ethernet-based access rings.
- Virtual Private LAN Services (VPLS): VPLS is a class of VPN that supports the connection of multiple sites in a single, bridged domain over a managed IP/MPLS network. It presents an Ethernet interface to customers, simplifying the LAN and WAN boundary for service providers and customers, and enabling rapid and flexible service provisioning because the service bandwidth is not tied to the physical interface. All services in a VPLS appear to be on the same LAN, regardless of location.
- Hierarchical VPLS (H-VPLS): H-VPLS provides a level of hierarchy at the edge of the VPLS network for increased scale. QinQ access and H-VPLS pseudowire access options are supported.
- Virtual Private WAN Services/Ethernet over MPLS (VPWS/EoMPLS): EoMPLS transports Ethernet frames across an MPLS core using pseudowires. Individual EFPs or an entire port can be transported over the MPLS backbone using pseudowires to an egress interface or subinterface.
- Pseudowire redundancy: Pseudowire redundancy supports the definition of a backup pseudowire to protect a primary pseudowire that fails.
- Multisegment pseudowire stitching: Multisegment pseudowire stitching is a method for interworking two pseudowires together to form a cross-connect relationship.
- IPv4 Multicast: IPv4 Multicast supports Internet Group Management Protocol Versions 2 and 3 (IGMPv2/v3), Protocol Independent Multicast Source Specific Multicast (SSM) and Sparse Mode (SM), Multicast Source Discovery Protocol (MSDP), and Anycast Rendezvous Point (RP).
- IGMP v2/v3 Snooping: This Layer 2 mechanism efficiently tracks multicast membership on an L2VPN network. Individual IGMP joins are snooped at the VLAN level or pseudowire level and then summarizes results into a single upstream join message. In residential broadband deployments, this feature enables the network to send only channels that are being watched to the downstream users

Flexible Ethernet

The router uses Ethernet as its transport mechanism, this offers the following:

- Ethernet virtual connections (EVCs): Ethernet services are supported using individual EVCs to carry traffic belonging to a specific service type or end user through the network. You can use EVC-based services in conjunction with MPLS-based L2VPNs and native IEEE bridging deployments.
- Flexible VLAN classification: VLAN classification into Ethernet flow points (EFPs) includes single-tagged VLANs, double-tagged VLANs (QinQ and IEEE 802.1ad), contiguous VLAN ranges, and noncontiguous VLAN lists.
- IEEE Bridging: The software supports native bridging based on IEEE 802.1Q, IEEE 802.1ad, and QinQ VLAN encapsulation mechanisms on the router.
- IEEE 802.1s Multiple Spanning Tree (MST): MST extends the IEEE 802.1w Rapid Spanning Tree Protocol (MSTP) to multiple spanning trees, providing rapid convergence and load balancing.

- **MST Access Gateway:** This feature provides a resilient, fast-convergence mechanism for aggregating and connecting to Ethernet-based access rings.

L2VPN

The Cisco ASR 9000 Series router uses L2VPNs, this offers the following:

- **Virtual Private LAN Services (VPLS):** VPLS is a class of VPN that supports the connection of multiple sites in a single, bridged domain over a managed IP/MPLS network. It presents an Ethernet interface to customers, simplifying the LAN and WAN boundary for service providers and customers, and enabling rapid and flexible service provisioning because the service bandwidth is not tied to the physical interface. All services in a VPLS appear to be on the same LAN, regardless of location.
- **Hierarchical VPLS (H-VPLS):** H-VPLS provides a level of hierarchy at the edge of the VPLS network for increased scale. QinQ access and H-VPLS pseudowire access options are supported.
- **Virtual Private WAN Services/Ethernet over MPLS (VPWS/EoMPLS):** EoMPLS transports Ethernet frames across an MPLS core using pseudowires. Individual EFPs or an entire port can be transported over the MPLS backbone using pseudowires to an egress interface or subinterface.
- **Pseudowire redundancy:** Pseudowire redundancy supports the definition of a backup pseudowire to protect a primary pseudowire that fails.
- **Multisegment pseudowire stitching:** Multisegment pseudowire stitching is a method for interworking two pseudowires together to form a cross-connect relationship.

Multicast

The Cisco ASR 9000 Series router supports multicast, this offers the following:

- **IPv4 Multicast:** IPv4 Multicast supports Internet Group Management Protocol Versions 2 and 3 (IGMPv2/v3), Protocol Independent Multicast Source Specific Multicast (SSM) and Sparse Mode (SM), Multicast Source Discovery Protocol (MSDP), and Anycast Rendezvous Point (RP).
- **IGMP v2/v3 Snooping:** This Layer 2 mechanism efficiently tracks multicast membership on an L2VPN network. Individual IGMP joins are snooped at the VLAN level or pseudowire level and then summarizes results into a single upstream join message. In residential broadband deployments, this feature enables the network to send only channels that are being watched to the downstream users.

OAM

The Cisco ASR 9000 Series router supports different types of operations, administration, and maintenance (OAM), this offers the following:

- **E-OAM (IEEE 802.3ah):** Ethernet link layer OAM is a vital component of EOAM that provides physical-link OAM to monitor link health and assist in fault isolation. Along with IEEE 802.1ag, Ethernet link layer OAM can be used to assist in rapid link-failure detection and signaling to remote end nodes of a local failure.
- **E-OAM (IEEE 802.1ag):** Ethernet Connectivity Fault Management is a subset of EOAM that provides numerous mechanisms and procedures that allow discovery and verification of the path through IEEE 802.1 bridges and LANs.
- **MPLS OAM:** This protocol supports label-switched-path (LSP) ping, LSP TraceRoute, and virtual circuit connectivity verification (VCCV).

Layer 3 routing

The Cisco ASR 9000 Series router runs Cisco IOS XR Software which supports Layer 3 routing and a range of IPv4 services and routing protocols, including the following:

- Intermediate System-to-Intermediate System (IS-IS)
- Open Shortest Path First (OSPF)
- static routing
- IPv4 Multicast
- Routing Policy Language (RPL)
- Hot Standby Router Protocol (HSRP)
- Virtual Router Redundancy Protocol (VRRP)

MPLS VPN

The Cisco ASR 9000 Series router supports MPLS VPN, this offers the following:

- **MPLS L3VPN:** The IP VPN feature for MPLS allows a Cisco IOS Software or Cisco IOS-XR Software network to deploy scalable IPv4 Layer 3 VPN backbone services. An IP VPN is the foundation that companies use for deploying or administering value-added services, including applications and data hosting network commerce and telephony services to business customers.
- **Carrier Supporting Carrier (CSC):** CSC allows a MPLS VPN service provider to connect geographically isolated sites using another backbone service provider and still maintain a private address space for its customer VPNs. It is implemented as defined by IETF RFC 4364.

QoS

The Cisco ASR 9000 Series router supports many types of quality of service (QoS), this offers the following:

- **QoS:** Comprehensive QoS support with up to 3 million queues, Class-Based Weighted Fair Queuing (CBWFQ) based on a three-parameter scheduler, Weighted Random Early Detection (WRED), two-level strict priority scheduling with priority propagation, and 2-rate, 3-color (2R3C) Policing are all supported.
- **Cisco IOS XR Software:** This software supports a rich variety of QoS mechanisms, including policing, marking, queuing, dropping, and shaping. Additionally, the operating systems support Modular QoS CLI (MQC). Modular CLI is used to configure various QoS features on various Cisco platforms.
- **H-QoS:** Four-level H-QoS support is provided for EVCs with the following hierarchy levels: port, group of EFPs, EFP, and class of service. This level of support allows for per-service and per-end user QoS granularity.

MPLS TE

The Cisco ASR 9000 Series router supports MPLS TE, this offers the following:

- **MPLS TE:** Cisco IOS XR Software supports MPLS protocols such as Traffic Engineering/Fast Reroute (TE-FRR), Resource Reservation Protocol (RSVP), Label Distribution Protocol (LDP), and Targeted Label Distribution Protocol (T-LDP).

- **MPLS TE Preferred Path:** Preferred tunnel path functions let you map pseudowires to specific TE tunnels. Attachment circuits are cross-connected to specific MPLS TE tunnel interfaces instead of remote provider-edge router IP addresses (reachable using Interior Gateway Protocol [IGP] or Label Distribution Protocol [LDP]).

High Availability

The Cisco ASR 9000 Series router is intended for use in networks that require high-availability. It is designed to provide high MTBF (Mean Time Between Failures) and low MTTR (Mean Time To Resolve) rates. This minimizes outages or and maximizes availability. The Cisco ASR 9000 Series router achieves this using the following:

- Component redundancy
 - Duplex power supplies
 - Cooling systems
- Fault detection
- Management features
- High availability features
 - Non-stop forwarding (NSF)—Cisco IOS XR Software supports forwarding without traffic loss during a brief outage of the control plane through signaling and routing protocol implementations for graceful restart extensions as standardized by the IETF, NSF requires neighboring nodes to be NSF-aware.
 - Process restartability (minimum disruption restart)
 - Stateful switchovers
 - In-service software upgrades
 - MPLS TE FRR
 - Bidirectional Forwarding Detection (BFD)
 - Standard IEEE 802.3ad link aggregation bundles

System Configurations

The router runs Cisco IOS XR Software on the following standalone chassis types, available in AC or DC versions:

- a 6-slot chassis
- a 10-slot chassis

Figure 1-1 6-Slot Chassis

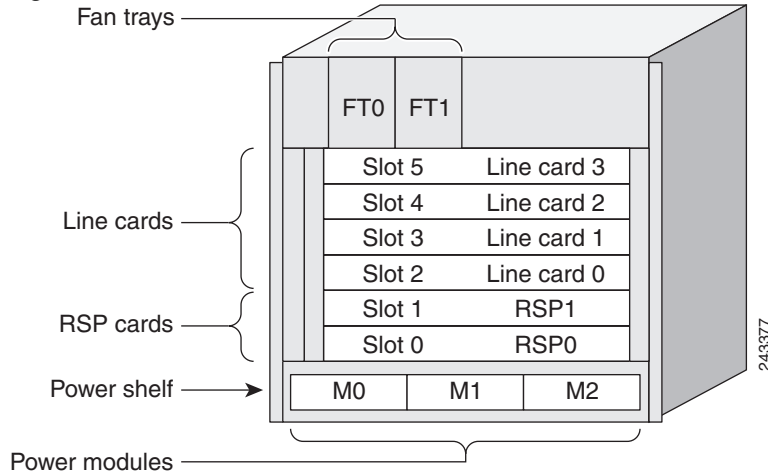
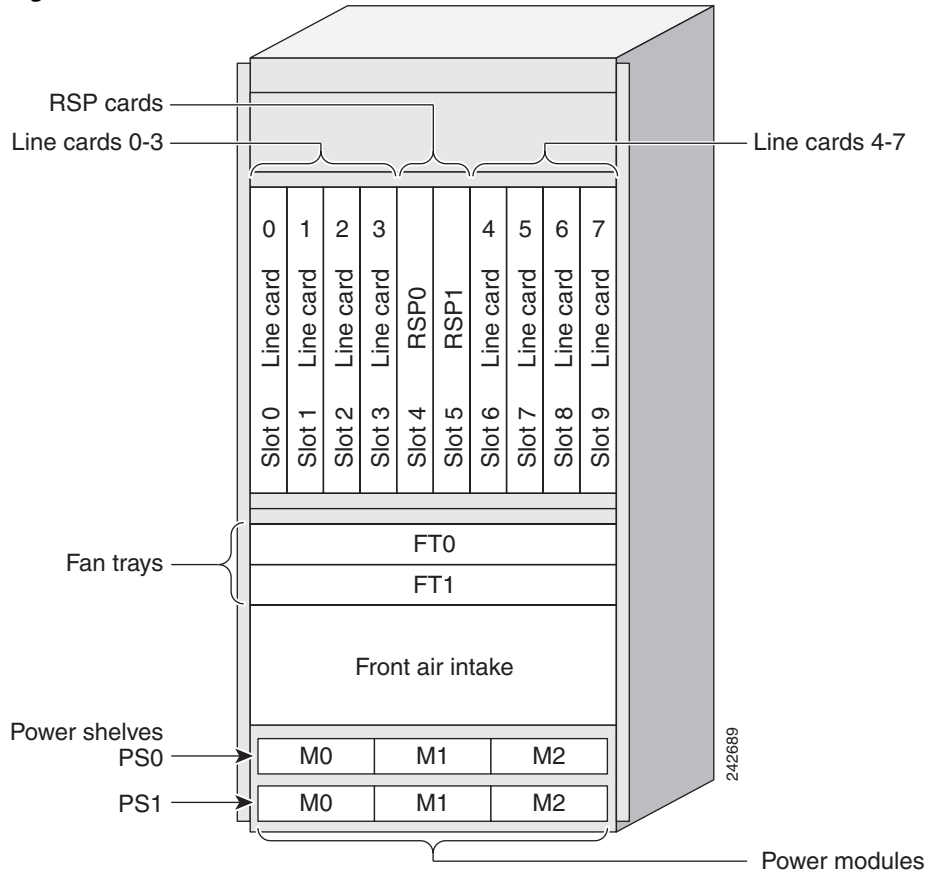

Figure 1-2 10-Slot Chassis



Each chassis type supports 40G per slot, and can share route-switch processors (RSPs) and line cards (LCs), which are interchangeable. In each chassis, two slots are designated for RSPs, while the remaining slots accommodate line cards that carry the traffic. The RSPs interconnect the line cards and provide chassis management and control. Any line card can be used as a network-facing trunk card, a subscriber-facing card, or it can provide any other form on connectivity.

The router uses the following line cards:

- 40x1GE Ethernet line card
- 4x10GE Ethernet line card
- 8x10GE Ethernet line card

Management and Security

In addition to the management and security features listed below, the router has administrative options, like assigning Task IDs, that control who can perform router tasks.

Manageability

- **Command-Line Interface**—The CLI is a user interface for monitoring and maintaining the router and also for configuring basic router features.
- **Simple Network Management Protocol**—SNMP is an application-layer protocol that facilitates management information exchange between network devices.
- **MIBs**—Management Information Bases are databases of objects that can be managed on a device. MIBs include the following: IP-MIB (RFC4293), CISCO-BULK-FILE-MIB, CISCO-CONFIG-COPY-MIB, CISCO-CONFIG-MAN-MIB, CISCO-ENHANCED-IMAGE-MIB, CISCO-ENHANCED-MEMORY-POOL-MIB, CISCO-ENTITY-FRU-CONTROL-MIB, CISCO-ENTITY-SENSOR-MIB, ENTITY-MIB, CISCO-ENTITY-ASSET-MIB, ENTITY-STATE-MIB, ENTITY-SENSOR-MIB, CISCO-ENTITY-ALARM-MIB, CISCO-FLASH-MIB, CISCO-IF-EXTENSION-MIB, CISCO-MEMORY-POOL-MIB, CISCO-RF-MIB (1:1 RP Card), CISCO-SYSLOG-MIB, EVENT-MIB, IF-MIB as well as RFC1213-MIB, SNMP-COMMUNITY-MIB, SNMP-FRAMEWORK-MIB, SNMP-NOTIFICATION-MIB, SNMP-TARGET-MIB, IPv6-MIB, BRIDGE-MIB, DOT3-OAM-MIB, CISCO-IETF-PW-MIB, CISCO-CLASS-BASED-QOS-MIB, ETHERLIKE-MIB, BGP4-MIB Including Cisco extensions, MPLS TE STD MIB, TE-FRR-MIB, and CISCO-IETF-IPMROUTE-MIB, IEEE-8021-CFM-MIB, DOT3-OAM-MIB
- **Trivial File Transfer Protocol**—TFTP allows files to be transferred from one computer to another over a network, usually without the use of client authentication (for example, username and password).
- **Network Time Protocol**—NTP synchronizes timekeeping among a set of distributed time servers.
- **Cisco IOS XR Software manageability**: This feature provides industry-standard management interfaces, including a modular command-line interface (CLI), Simple Network Management Protocol (SNMP), and native XML interfaces.
- **Cisco Active Network Abstraction (ANA)**: Cisco ANA is a flexible, vendor-neutral network resource-management solution for a multitechnology, multiservice network environment. Operating between the network and the operations-support-system (OSS) layer, Cisco ANA aggregates virtual network elements (VNEs) into a software-based virtual network, much as real network elements create the real-world network. Cisco ANA dynamically discovers network components and tracks the status of network elements in near real time. Cisco ANA offers service providers:
 - Simplified integration of OSS applications with network information
 - A flexible common infrastructure for managing network resources
 - Consistent procedures and interfaces for all network elements

Security

- Cisco IOS XR Software: This software provides comprehensive network security features, including ACLs; control-plane protection; routing authentications; authentication, authorization, and accounting (AAA); TACACS+; IP Security (IPSec); Secure Shell (SSH) Protocol; SNMPv3; and leading Routing Policy Language (RPL) support.
- Layer 2 ACLs: You can use this security feature to filter packets under an EVC based on MAC addresses.
- Layer 3 ACLs: This feature matches ACLs by IPv4 protocol packet attributes.
- Security: Many critical security features are supported:
 - Standard IEEE 802.1ad Layer 2 Control Protocol (L2CP) and bridge-protocol-data-unit (BPDU) filtering
 - MAC limiting per EFP or bridge domain
 - Unicast, multicast, and broadcast storm control blocking on any interface or port
 - Unknown Unicast Flood Blocking (UUFB)
 - Dynamic Host Configuration Protocol (DHCP) Snooping
 - Unicast Reverse Path Forwarding (URPF)
 - Control-plane security
- Secure Shell (SSH)
- Authorization, Admission, Accounting (AAA)
- Control Plane Policing (CoPP)

Initial Router Configuration

The initial configuration of the Cisco ASR 9000 Series router is determined automatically by the software when you boot the router; you need not set up any general configuration information. Also there is no explicit configuration needed to make a particular RSP active. It becomes the active RSP when chosen automatically by the software upon boot.

Since there are not multiple RSP pairs in this router, the only RSP choices are RSP0 and RSP1. Typically, the lower numbered slot is the chosen RSP. If that RSP is not available the software chooses the RSP in the other slot as the route process controller, making it the primary RSP. During fail over or switch over, the active role migrates to the standby RSP.

Management Interfaces

Although there is no need to set up general router configuration information, you do need to configure management interfaces manually. Configure management ports on RSP0, RSP1, or both at the same time:

- Telnet
- Secure Shell (SSH)
- Console Server

The router provides different router management interfaces, described in the following sections:

- [Command-Line Interface, page 1-10](#)
- [Extensible Markup Language API, page 1-10](#)
- [Simple Network Management Protocol, page 1-10](#)

Command-Line Interface

The CLI is a user interface for monitoring and maintaining the router and also for configuring basic router features. Through the CLI you execute the Cisco IOS XR commands.

All procedures in this guide use CLI. Before you can use other router management interfaces, first use the CLI to install and configure those interfaces. Guidelines for using CLI to configure the router are discussed in the following chapters:

- [Chapter 3, “Configuring General Router Features”](#)
- [Chapter 4, “Configuring Additional Router Features”](#)
- [Chapter 5, “CLI Tips, Techniques, and Shortcuts”](#)

For more CLI procedures, like hardware interface and software protocol management tasks, see the Cisco IOS XR Software documents listed in [“Conventions” section on page xii](#).

Extensible Markup Language API

The Extensible Markup Language (XML) application programming interface (API) is an XML interface used for rapid development of client applications and perl scripts to manage and monitor the router. Client applications can configure the router or request status information from the router by encoding a request in XML API tags and sending it to the router. The router processes the request and sends the response to the client in the form of encoded XML API tags. The XML API supports readily available transport layers, including Telnet, Secure Shell (SSH) and Secure Socket Layer (SSL) transport.

For more information, see the Cisco IOS XR Software documents listed in the [“Conventions” section on page xii](#).

Simple Network Management Protocol

Simple Network Management Protocol (SNMP) is an application-layer protocol that facilitates management information exchange between network devices. By using SNMP-transported data (such as packets per second and network error rates), network administrators can manage network performance, find and solve network problems, and plan for network growth.

The Cisco IOS XR Software supports SNMP v1, v2c, and v3. SNMP is part of a larger architecture called the Internet Network Management Framework (NMF), which is defined in Internet documents called RFCs. The SNMPv1 NMF is defined by RFCs 1155, 1157, and 1212, and the SNMPv2 NMF is defined by RFCs 1441 through 1452. For more information on SNMP v3, see RFC 2272 and 2273.

SNMP is a popular protocol for managing diverse commercial internetworks and those used in universities and research organizations. SNMP-related standardization activity continues even as vendors develop and release state-of-the-art, SNMP-based management applications. SNMP is a relatively simple protocol, yet its feature set is sufficiently powerful to handle the difficult problems presented in trying to manage the heterogeneous networks of today.

For more information, see the Cisco IOS XR Software documents listed in the [“Conventions” section on page xii](#).

Connecting to the Router Through the Console Port

The first time you connect to a new Cisco ASR 9000 Series router with Cisco IOS XR software, connect through the Console port. Although typical router configuration and management take place using an Ethernet port, you must configure the console port for your LAN before it can be used.

Because a new router has no name, IP address, or other credentials, use a terminal to connect through the Console port, setting the speed to 9600. The remote terminal setting has to match the 9600 value.

After you connect through the Console port, configure the management ports with their IP addresses. Then you can use either SSH or Telnet to connect to the router.

**Note**

confreg 0x0 reverts to the default speed setting. If you change it from the default of 9600, you must reset it afterwards.

To connect to the router through the Console port, perform the following procedure.

SUMMARY STEPS

1. Power on the router.
2. **Connect a terminal to the Console port.**
3. Start the terminal emulation program.
4. Press **Enter**.
5. Log in to the router.
6. **admin**
7. **show dsc**

DETAILED STEPS

	Command or Action	Purpose
Step 1	Power on the router.	Starts the router. <ul style="list-style-type: none"> This step is required only if the power is not on. For information on power installation and controls, see the hardware documentation listed in the “Conventions” section on page xii.
Step 2	Connect a terminal to the Console port.	Establishes a communications path to the router. <ul style="list-style-type: none"> During the initial setup, you can communicate with the router only through the Console port. The router Console port is designed for a serial cable connection to a terminal or a computer that is running a terminal emulation program. The terminal settings are: <ul style="list-style-type: none"> Bits per second: 9600 Data bits: 8 Parity: None Stop bit: 2 Flow control: None For information on the cable requirements for the Console port, see the hardware documentation listed in the “Conventions” section on page xii.
Step 3	Start the terminal emulation program.	(Optional.) Prepares a computer for router communications. <ul style="list-style-type: none"> The step is not required if you are connecting through a terminal. Terminals send keystrokes to and receive characters from another device. If you connect a computer to the Console port, you must use a terminal emulation program to communicate with the router. For instructions on using the terminal emulation program, see the documentation for that program.
Step 4	Press Enter .	Initiates communication with the router. <ul style="list-style-type: none"> If no text or router prompt appears when you connect to the console port, press Enter to initiate communications. If no text appears when you press Enter, give the router more time to complete the initial boot procedure, then press Enter. If the prompt gets lost among display messages, press Enter again. The router displays the prompt: <code>Username:</code>

	Command or Action	Purpose
Step 5	Log in to the router.	Establishes your access rights for the router management session. <ul style="list-style-type: none"> Type the root-system username and password or the username and password provided by your system administrator. After you log in, the router displays the CLI prompt, which is described in “CLI Prompt” section on page 3-6.
Step 6	<code>admin</code> Example: RP/0/RSP0/CPU0:router# admin	Places the router in administration EXEC mode.
Step 7	<code>show dsc</code> Example: RP/0/RSP0/CPU0:RO-A(admin)#sh dsc NODE ROLE =====	Displays the RSP information for the router so that you can verify that you have connected successfully to the console port.

Configuring Gigabit Ethernet and 10-Gigabit Ethernet Interfaces

After connecting to the router, you need to configure Gigabit Ethernet and Ten Gigabit Ethernet interfaces manually. Because these interfaces are for data traffic only, not management traffic, you cannot use SSH or Telnet to an IP address that is part of the Gigabit Ethernet and 10-Gigabit Ethernet interfaces.

Where to Go Next

Once you have logged into the router, you are ready to perform general router configuration as described in “CLI Prompt” section on page 3-6.

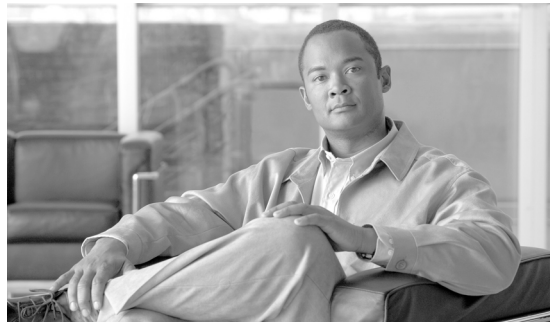

CHAPTER 2

Bringing Up Cisco IOS XR Software on the Router

This chapter provides instructions for bringing up Cisco IOS XR Software on the router for the first time.

Contents

- [Prerequisites, page 2-1](#)
- [Bringing Up and Configuring the Router, page 2-2](#)
- [Verifying the System After Initial Boot, page 2-4](#)
- [Where to Go Next, page 2-8](#)

Prerequisites

The following sections describe the software and hardware requirements for bringing up the router running Cisco IOS XR Software Release 3.7.

Software Requirements

The system requires compatible ROM Monitor firmware on all RPs.

**Caution**

The ROM Monitor firmware on all RPs must be compatible with the Cisco IOS XR Software release installed on the router. If the router is brought up with an incompatible version of the ROM Monitor software, the standby RP may fail to boot. For instructions to overcome a boot block in the standby RSP, see the *Cisco ASR 9000 Series Aggregation Series Router ROM Monitor Guide*.

Hardware Prerequisites and Documentation

The Cisco IOS XR Software runs on the configuration listed in the [“System Configurations” section on page 1-6](#). Before a router can be started, the following hardware management procedures must be completed:

- Site preparation
- Equipment unpacking
- Router installation

For information on how to complete these procedures for your router equipment, see the hardware documents listed in the [“Conventions” section on page xii](#).

Bringing Up and Configuring the Router

To bring up a standalone router, you need to connect to the router and configure the root-system username and password, as described in the following procedure:

SUMMARY STEPS

1. Establish a connection to the Console port.
2. Type the username for the root-system login and press **Enter**.
3. Type the password for the root-system login and press **Enter**.
4. Log in to the router.

DETAILED STEPS

	Command or Action	Purpose
Step 1	Establish a connection to the Console port.	Initiates communication with the router. <ul style="list-style-type: none"> For instructions on connecting to the Console port, see the “Connecting to the Router Through the Console Port” section on page 1-11. When you have successfully connected to the router through the Console port, the router displays the prompt: <code>Username:</code>
Step 2	Type the username for the root-system login and press Enter .	Sets the root-system username, which is used to log in to the router.
Step 3	Type the password for the root-system login and press Enter .	Creates an encrypted password for the root-system username. <p>Note This password can be changed with the secret command.</p>
Step 4	Retype the password for the root-system login and press Enter .	Allows the router to verify that you have entered the same password both times. <ul style="list-style-type: none"> If the passwords do not match, the router prompts you to repeat the process.
Step 5	Log in to the router.	Establishes your access rights for the router management session. <ul style="list-style-type: none"> Type the root-system username and password that were created earlier in this procedure. After you log in, the router displays the CLI prompt, which is described in the “CLI Prompt” section on page 3-6.

Examples

The following example shows the root-system username and password configuration for a new router, and it shows the initial log in:

```

--- Administrative User Dialog ---

Enter root-system username: cisco
Enter secret:
Enter secret again:
RP/0/0/CPU0:Jan 10 12:50:53.105 : exec[65652]: %MGBL-CONFIG-6-DB_COMMIT :
'Administration configuration committed by system'. Use 'show configuration
commit changes 2000000009' to view the changes.
Use the 'admin' mode 'configure' command to modify this configuration.

User Access Verification

Username: cisco
Password:
RP/0/0/CPU0:ios#

```

The secret line in the configuration command script shows that the password is encrypted. When you type the password during configuration and login, the password is hidden.

Verifying the System After Initial Boot

To verify the status of the router, perform the following procedure:

SUMMARY STEPS

1. **show version**
2. **admin**
3. **show platform** [*node-id*]
4. **exit**
5. **show redundancy**
6. **show environment**

DETAILED STEPS

	Command or Action	Purpose
Step 1	show version Example: RP/0/RSP0/CPU0:router# show version	Displays information about the router, including image names, uptime, and other system information.
Step 2	admin Example: RP/0/RSP0/CPU0:router# admin	Places the router in administration EXEC mode, displays information about the status of cards and modules installed in the router, and terminates administration EXEC mode.
Step 3	show platform [<i>node-id</i>] Example: RP/0/RSP0/CPU0:router# show platform	A card module is also called a node. When a node is working properly, the status of the node in the State column is IOS XR RUN. Use the show platform <i>node-id</i> command to display information for a specific node. Replace <i>node-id</i> with a node name from the show platform command Node column. Note To view the status of all cards and modules, the show platform command must be executed in administration EXEC mode.
Step 4	exit Example: RP/0/RSP0/CPU0:router# exit	Exits the EXEC mode.

	Command or Action	Purpose
Step 5	show redundancy Example: RP/0/RSP0/CPU0:router# show redundancy	Displays the state of the primary (active) and standby (inactive) RPs, including the ability of the standby to take control of the system. <ul style="list-style-type: none"> If both RPs are working correctly, one node displays active role, the Partner node row displays standby role, and the Standby node row displays Ready.
Step 6	show environment Example: RP/0/RSP0/CPU0:router# show environment	Displays information about the hardware attributes and status.

Examples of show Commands

The following sections provide examples of **show** commands:

- [show version Command: Example, page 2-5](#)
- [show platform Command: Example, page 2-6](#)
- [show redundancy Command: Example, page 2-7](#)
- [show environment Command: Example, page 2-7](#)

show version Command: Example

To view basic information about the router configuration, type the **show version** command in EXEC mode, as shown in the following example:

```
RP/0/RSP0/CPU0:router# show version

Cisco IOS XR Software, Version 3.7.2.10I[FCI_DT_IMAGE]
Copyright (c) 2008 by Cisco Systems, Inc.

ROM: System Bootstrap, Version 0.63(20081010:215422) [ASR9K ROMMON],

router uptime is 1 week, 1 day, 10 hours, 31 minutes
System image file is "bootflash:disk0/asr9k-os-mbi-3.7.2.10I/mbiasr9k-rp.vm"

cisco ASR9K Series (MPC8641D) processor with 4194304K bytes of memory.
MPC8641D processor at 1333MHz, Revision 2.2

40 GigabitEthernet/IEEE 802.3 interface(s)
2 Ethernet/IEEE 802.3 interface(s)
12 TenGigabitEthernet/IEEE 802.3 interface(s)
219k bytes of non-volatile configuration memory.
975M bytes of compact flash card.
33994M bytes of hard disk.
1605616k bytes of disk0: (Sector size 512 bytes).
1605616k bytes of disk1: (Sector size 512 bytes).
```

```

Configuration register on node 0/RSP0/CPU0 is 0x2
Boot device on node 0/RSP0/CPU0 is disk0:
--More--

```

show platform Command: Example

The **show platform** command displays information on router resources. In EXEC mode, the **show platform** command displays the resources assigned to the RP you are managing. In administration EXEC mode, the **show platform** command displays all router resources.

```
RP/0/RSP0/CPU0:router# show platform
```

Node	Type	State	Config State
0/RSP0/CPU0	A9K-RSP-4G-HDD(Active)	IOS XR RUN	PWR,NSHUT,MON
0/1/CPU0	A9K-40GE-B	IOS XR RUN	PWR,NSHUT,MON
0/4/CPU0	A9K-8T/4-B	IOS XR RUN	PWR,NSHUT,MON
0/6/CPU0	A9K-4T-B	IOS XR RUN	PWR,NSHUT,MON

The following administration EXEC mode example shows all router nodes:

```
RP/0/RSP0/CPU0:router# admin
```

```
RP/0/RSP0/CPU0:router(admin)# show platform
```

Node	Type	State	Config State
0/RSP0/CPU0	A9K-RSP-4G-HDD(Active)	IOS XR RUN	PWR,NSHUT,MON
0/FT0/SP	FAN TRAY	READY	
0/FT1/SP	FAN TRAY	READY	
0/1/CPU0	A9K-40GE-B	IOS XR RUN	PWR,NSHUT,MON
0/4/CPU0	A9K-8T/4-B	IOS XR RUN	PWR,NSHUT,MON
0/6/CPU0	A9K-4T-B	IOS XR RUN	PWR,NSHUT,MON
0/PM0/SP	A9K-3KW-AC	READY	PWR,NSHUT,MON
0/PM1/SP	A9K-3KW-AC	READY	PWR,NSHUT,MON
0/PM2/SP	A9K-3KW-AC	READY	PWR,NSHUT,MON

The following example shows information for a single node in the router:

```
RP/0/RSP0/CPU0:router# show platform 0/1/CPU0
```

Node	Type	State	Config State
0/1/CPU0	A9K-40GE-B	IOS XR RUN	PWR,NSHUT,MON

For more information on node IDs, see *Cisco IOS XR System Management Configuration Guide*.

For more information on the **show platform** command, see *Cisco IOS XR Interface and Hardware Component Command Reference*.

show redundancy Command: Example

To view information about the active and standby (inactive) RPs, type the **show redundancy** command as follows:

```
RP/0/RSP0/CPU0:router# show redundancy

Redundancy information for node 0/RSP0/CPU0:
=====
Node 0/RSP0/CPU0 is in ACTIVE role
Partner node (0/RSP1/CPU0) is in STANDBY role
Standby node in 0/RSP1/CPU0 is ready

Reload and boot info
-----
RP reloaded Wed Feb 15 13:58:32 2008: 1 week, 6 days, 22 hours, 49 minutes ago
Active node booted Wed Feb 15 13:58:32 2008: 1 week, 6 days, 22 hours, 49 minutes ago
Standby node boot Wed Feb 15 13:59:00 2008: 1 week, 6 days, 22 hours, 49 minutes ago
Standby node last went not ready Wed Mar  1 07:40:00 2008: 5 hours, 8 minutes ago
Standby node last went ready Wed Mar  1 07:40:00 2008: 5 hours, 8 minutes ago
There have been 0 switch-overs since reload
```

show environment Command: Example

To view environmental monitor parameters for the system, use the **show environment** command in EXEC or administration EXEC mode.

Use the following command syntax:

show environment [options]

Type the **show environment ?** command to view the command options.

The following example shows a router's temperature information:

```
RP/0/RSP0/CPU0:router# show environment temperatures

R/S/I  Modules          Inlet          Hotspot
          Temperature   Temperature
          (deg C)       (deg C)

0/1/*
      host          28.1          35.7
0/RSP0/*
      host          24.0          33.5

0/4/*
      host          26.7          35.0
0/6/*
      host          30.0          39.1
```

The following example shows a router's LED status:

```
RP/0/RSP0/CPU0:router# show environment leds

R/S/I  Modules LED          Status
```

```
0/RSP0/*
  host    Critical-Alarm 0
  host    Major-Alarm   0
  host    Minor-Alarm   0
  host    ACO            0
```

Where to Go Next

For information on configuring basic router features, see [“Configuring General Router Features” section on page 3-1](#).



CHAPTER 3

Configuring General Router Features

This chapter describes how to communicate with the router using command-line interface (CLI). This chapter also shows basic Cisco IOS XR Software configuration management.

Contents

- [Connecting to and Communicating with the Router, page 3-1](#)
- [Logging In to a Router, page 3-5](#)
- [Navigating Cisco IOS XR Software Command Modes, page 3-10](#)
- [Managing Configuration Sessions, page 3-16](#)
- [Configuring the Management Ethernet Interface, page 3-32](#)
- [Manually Setting the Router Clock, page 3-36](#)
- [Where to Go Next, page 3-38](#)

Connecting to and Communicating with the Router

To use a router running Cisco IOS XR Software, first connect to it using a terminal or a PC. Before you connect to the router, determine which entity to manage. You can manage router hardware or named RSPs.

Connections are made through a direct physical connection to the Console port or through management interfaces. To connect through the management interfaces, establish IP addresses and a default gateway.

The first time a router starts, use a direct connection to the Console port to type the configuration information. When directly connected to the Console port, enter CLI commands at a terminal or computer running terminal emulation software. This direct Console port connection is useful for debugging as well.

Configure the Management Ethernet interface, described in the [“Configuring the Management Ethernet Interface” section on page 3-32](#). Router management and configuration can take place over an Ethernet network connected to the Management Ethernet interface. Simple Network Management Protocol (SNMP) agents also use the network connection.

You can use the modem connection for remote communications with the router. If the Management Ethernet interface fails, the modem connection is an alternate path.

The following sections describe how to connect to the router:

- [Connecting Through the Console Port, page 3-2](#)
- [Connecting Through a Terminal Server, page 3-3](#)
- [Connecting Through the Management Ethernet Interface, page 3-5](#)

Connecting Through the Console Port

To connect to the router through the console port, perform the following procedure.

SUMMARY STEPS

1. Identify the active RSP.
2. Connect a terminal to the Console port of the active RSP.
3. Start the terminal emulation program.
4. Press **Enter**.
5. Log in to the router.

DETAILED STEPS

	Command or Action	Purpose
Step 1	Identify the active RSP.	Identifies the RSP to which you must connect in the next step. There are two RSPs: RSP0 and RSP1. One is active RSP, the other is standby.
Step 2	Connect a terminal to the Console port of the active RSP.	Establishes a communications path to the router. <ul style="list-style-type: none"> • During initial setup, communicate with the router only through the Console port of the active RSP. • The Console port uses a serial cable connection to a terminal or a computer running terminal emulation. • The terminal settings are: <ul style="list-style-type: none"> – Bits per second: 9600/9600 (can be either value, but usually 9600) – Data bits: 8 – Parity: None – Stop bit: 1 – Flow control: None • For cable requirements for the Console port, see hardware documentation listed in the “Conventions” section on page xii.

	Command or Action	Purpose
Step 3	Start the terminal emulation program.	(Optional) Prepares a computer for router communications. <ul style="list-style-type: none"> The step is not required if you are connecting through a terminal. Terminals send keystrokes to and receive characters from another device. If you connect a computer to the Console port, use terminal emulation to communicate with the router. For instructions on using a terminal emulation program, see its documentation.
Step 4	Press Enter .	Initiates communication with the router. <ul style="list-style-type: none"> If no text or router prompt appears when you connect to the Console port, press Enter to initiate communications. If no text appears when you press Enter and the router has been started recently, give the router more time to complete the initial boot procedure, then press Enter. The router displays the prompt: <code>Username:</code>
Step 5	Log in to the router.	Establishes your access rights for the router management session. <ul style="list-style-type: none"> Type your username and password, as described in the “Logging In to a Router” section on page 3-5. After you log in, the router displays the CLI prompt, which is described in the “CLI Prompt” section on page 3-6.

Connecting Through a Terminal Server

A terminal server connection provides a way to remotely access the Console port. It is less expensive to connect to the router through the Management Ethernet interface (because you do not have the additional cost of a terminal server). However, if you need to perform tasks that require Console port access from a remote location, a terminal server is the best method.

The procedure for connecting to the router through a terminal server is similar to the procedure for directly connecting through the Console port. For both connection types, the physical connection takes place through the Console port. The difference is that the terminal server connects directly to the Console port, and you must use a Telnet session to establish communications through the terminal server to the router.

To establish a connection through a terminal server, perform the following procedure.

SUMMARY STEPS

1. Install and configure the terminal server.
2. Connect the terminal server to the Console port of the target RSP.
3. Power on the router.
4. Identify the target RSP.
5. **telnet** *access-server-address port*
6. Press **Enter**.
7. Log in to the router.

DETAILED STEPS

	Command or Action	Purpose
Step 1	Install and configure the terminal server.	<p>Prepares the terminal server for communications with the router and with Telnet clients.</p> <ul style="list-style-type: none"> This step is usually preformed once. For router access, users need the Telnet server IP address and port number for each RSP they access. For additional information on configuring terminal services, including terminal servers and templates, see the <i>Cisco ASR 9000 Series Aggregation Services Router System Management Configuration Guide</i>.
Step 2	Connect the terminal server to the Console port of the target RSP.	<p>Establishes a communications path between the terminal server and the router.</p> <ul style="list-style-type: none"> During the initial router setup, communicate with the router only through the Console port of the primary RSP. The router Console port uses a serial cable connection to a terminal or terminal server. The terminal settings are: <ul style="list-style-type: none"> Bits per second: 9600/9600 (can be either value, but usually 9600) Data bits: 8 Parity: None Stop bit: 1 Flow control: None For information on the cable requirements for the Console port, see the hardware documentation listed in the “Conventions” section on page xii.
Step 3	Power on the router.	<p>Starts the router.</p> <ul style="list-style-type: none"> This step is required only if the router power is not on. For information on power installation and controls, see hardware documentation listed in the “Conventions” section on page xii.
Step 4	Identify the target RSP.	<p>Identifies the RSP to which you connect in the next step.</p> <ul style="list-style-type: none"> The Cisco ASR 9000 Series router has two RSPs: RSP0 and RSP1. One is the active RSP, and the other is the standby.
Step 5	<code>telnet access-server-address port</code>	<p>Establishes a Telnet session with the terminal server.</p> <ul style="list-style-type: none"> Replace <i>access-server-address</i> with the IP address of the terminal server, and replace <i>port</i> with the terminal server port number that connects to the target RSP Console port.

	Command or Action	Purpose
Step 6	Press Enter .	(Optional) Initiates communications with the RSP. <ul style="list-style-type: none"> If no text or router prompt appears when you start the Telnet session, press Enter. The router displays the prompt: <code>Username:</code>
Step 7	Log in to the router.	Establishes your access rights for the router management session. Type a username and password when prompted.

Connecting Through the Management Ethernet Interface

The Management Ethernet interface allows you to manage the router using a network connection. Before using the Management Ethernet interface, configure it as described in the “[Configuring the Management Ethernet Interface](#)” section on page 3-33.

Once configured, the network connection takes place between client software on a workstation computer and a server process within the router. The type of client software you use depends on the server process you want to use. The Cisco IOS XR Software supports the following client and server services:

- Telnet clients can connect to a Telnet server in the router. The Telnet server is disabled by default and can be enabled with the **telnet ipv4 server** command in global configuration mode.
- Secure Shell (SSH) clients can connect to an SSH server in the router. The SSH server is disabled by default and can be enabled with the **ssh server** command in global configuration mode. The SSH server handles both Secure Shell Version 1 (SSHv1) and SSHv2 incoming client connections for IPv4 address families.

To start a Telnet network connection, you start the Telnet client software with a command similar to the following:

```
telnet ManagementEthernetInterfaceIPAddress
```

For specific instructions on connecting to the router through a Telnet or SSH client, see the instructions for that software.

Ask your system administrator for the IP address of the Management Ethernet interface.

When the Telnet session is established, the router prompts you to log in, as described in the “[Logging In to a Router](#)” section on page 3-5.

Logging In to a Router

The login process can require users to enter a password or a username and password before accessing the router CLI. The user groups to which your username is assigned determine which commands you can use.

Once you log in to the router, you can manage the entire router.

When you log in, the username and password may be validated by any of the following services:

- Usernames configured on the router (**username** command in global configuration mode)
- Root-system usernames that are configured
- Passwords configured for the router console and auxiliary ports (**password** or **secret** command in line configuration mode)

- A Remote Authentication Dial In User Service (RADIUS) server
- A Terminal Access Controller Access-Control System Plus (TACACS+) server

The username and password validation method that your router uses is determined by the router configuration. For information on configuring username and password validation methods, see the *Cisco ASR 9000 Series Aggregation Services Router System Security Configuration Guide*. For information on which username and password to use, see your system administrator.

To log in to the router, enter your username and password when prompted. For example:

```
User Access Verification
```

```
Username: cisco
Password: password
RP/0/RSP0/CPU0:router#
```



Note

Passwords are case sensitive. If you want to log in to the router using a root-system username, type the username in the following format: *username@admin*. To support admin login, local database authentication must be enabled with the **aaa authentication login remote local** command. For more information, see the *Cisco ASR 9000 Series Aggregation Services Router System Security Configuration Guide*.

After you log in, the router displays the CLI prompt, which is described in the “[CLI Prompt](#)” section on [page 3-6](#). The command set that you can use is determined by the privileges assigned to your username. For information on how privileges are assigned to usernames, see the *Cisco ASR 9000 Series Aggregation Services Router System Security Configuration Guide*.

CLI Prompt

After you log in, you see the CLI prompt for Cisco IOS XR Software. This prompt identifies the router to which you are issuing commands. The CLI prompt represents the path, through the router, to the CPU that executes the commands you enter. The syntax for the CLI prompt is: *type/rack/slot/module:router-name#*. The CLI prompt is described in [Table 3-1](#).

Table 3-1 CLI Prompt Description

Prompt Syntax Components	Description
<i>type</i>	Type of interface or card with which you are communicating. For most user communication tasks, the type is “RP.”
<i>rack</i>	Rack number. In a standalone router, the rack number is always “0.”
<i>slot</i>	Slot in which the RSP is installed. In a Cisco ASR 9000 Series router, the RSP physical slot number is “RSP0” or “RSP1.”
<i>module</i>	Entity on a card that executes user commands or communicates with a port (interface). For executing commands from the EXEC prompt, the module is the “CPU0” of the RP. “CPU0” also controls the forwarding and operating system (OS) functions for the system.
<i>router-name</i>	Hostname of the router. The hostname is usually defined during initial configuration of the router, as described in the “ Configuring the RSP Hostname ” section on page 3-31 .

For example, the following prompt indicates that the CLI commands are executed on the RP in rack 0, slot RSP0, by the “CPU0” module on a router named “router:”

```
RP/0/RSP0/CPU0:router#
```

User Access Privileges

When you log in to the router, your username and password are used to determine if you are authorized to access the router. After you successfully log in, your username is used to determine which commands you are allowed to use. The following sections provide information on how the router determines which commands you can use:

- [User Groups, Task Groups, and Task IDs, page 3-7](#)
- [Predefined User Groups, page 3-8](#)
- [Viewing Your User Groups and Task IDs, page 3-8](#)

User Groups, Task Groups, and Task IDs

The Cisco IOS XR software ensures security by combining tasks a user wants to perform (task IDs) into groups, defining which router configuration and management functions users can perform. This policy is enabled by the definition of:

- User groups—A collection of users that share similar authorization rights on a router.
- Task groups—Defined by a collection of task IDs for each class of action.
- Task IDs—Define permission to perform particular tasks; pooled into a task group that is then assigned to users.

The commands each user can perform are defined by the user groups to which he or she belongs. Commands for a particular feature, like access control lists, are assigned to tasks. Each task is uniquely identified by a task ID. If a user wants to use a particular command, his or her username must be associated with the appropriate task ID. The association between a username and a task ID takes place through two intermediate entities, the user group and task group.

The user group is a logical container used to assign the same task IDs to multiple users. Instead of assigning task IDs to each user, assign them to the user group. Then assign users to that user group. When a task is assigned to a user group, define the access rights for the commands associated with that task. These rights include “read,” “write,” “execute,” and “notify.”

The task group is also a logical container, but it groups tasks. Instead of assigning task IDs to each user group, you assign them to a task group. This allows you to quickly enable access to a specific set of tasks by assigning a task group to a user group. Users are not assigned to groups by default and must be explicitly assigned by an administrator.



Note

Only root-system users (root-lr users) or users associated with the WRITE:AAA task ID can configure task groups.

Predefined User Groups

Cisco IOS XR Software includes a set of predefined user groups that meets the needs of most organizations. These groups are described in [Table 3-2](#).

Table 3-2 *Predefined User Group Descriptions*

User Group	Privileges
root-system	Display and execute all commands for all RPs in the system.
root-lr	Display and execute all commands within a single RP.
sysadmin	Perform system administration tasks for the router, such as maintaining where the core dumps are stored or setting up the Network Time Protocol (NTP) clock.
netadmin	Configure network protocols, like Open Shortest Path First (OSPF) (usually used by network administrators).
operator	Perform day-to-day monitoring activities, and have limited configuration rights.
cisco-support	Debug and troubleshoot features (usually, used by Cisco Technical Support personnel).

For information on configuring user groups, see *Cisco ASR 9000 Series Aggregation Services Router System Security Configuration Guide*.

Viewing Your User Groups and Task IDs

To view user groups and task IDs associated with your account, enter **show user** in EXEC mode. [Table 3-3](#) summarizes this command's options.

Table 3-3 *Account Information Options*

Command	Description
show user	Displays your user name
show user tasks	Displays the task IDs assigned to your account
show user group	Displays the user groups assigned to your account
show user all	Displays all user groups and task ID information for your account
show aaa usergroup <i>group-name</i>	Displays the task IDs assigned to a user group

Examples

The following examples illustrate how to view user privileges:

- [show user Command: Example, page 3-9](#)
- [show user tasks Command: Example, page 3-9](#)
- [show user group Command: Example, page 3-9](#)
- [show user all Command: Example, page 3-9](#)
- [show aaa usergroup Command: Example, page 3-10](#)

show user Command: Example

To view your username, type the **show user** command:

```
RP/0/RSP0/CPU0:router# show user

cisco
```

show user tasks Command: Example

To view the tasks assigned to your account and your rights to those tasks, type the **show user tasks** command:

```
RP/0/RSP0/CPU0:router# show user tasks
Task:          aaa : READ    WRITE    EXECUTE  DEBUG
Task:          acl  : READ    WRITE    EXECUTE  DEBUG
Task:          admin : READ    WRITE    EXECUTE  DEBUG
Task:          ancp : READ    WRITE    EXECUTE  DEBUG
Task:          atm  : READ    WRITE    EXECUTE  DEBUG
Task:          basic-services : READ  WRITE    EXECUTE  DEBUG
Task:          bcdl : READ    WRITE    EXECUTE  DEBUG
Task:          bfd  : READ    WRITE    EXECUTE  DEBUG
Task:          bgp  : READ    WRITE    EXECUTE  DEBUG
Task:          boot : READ    WRITE    EXECUTE  DEBUG
Task:          bundle : READ  WRITE    EXECUTE  DEBUG
Task:          cdp  : READ    WRITE    EXECUTE  DEBUG
Task:          cef  : READ    WRITE    EXECUTE  DEBUG
Task:          cisco-support : READ  WRITE    EXECUTE  DEBUG (reserved)
Task:          config-mgmt : READ  WRITE    EXECUTE  DEBUG
Task:          config-services : READ  WRITE    EXECUTE  DEBUG
Task:          crypto : READ  WRITE    EXECUTE  DEBUG
Task:          diag  : READ    WRITE    EXECUTE  DEBUG
Task:          drivers : READ  WRITE    EXECUTE  DEBUG
Task:          dwdm  : READ    WRITE    EXECUTE  DEBUG
Task:          eem   : READ    WRITE    EXECUTE  DEBUG
Task:          eigrp : READ    WRITE    EXECUTE  DEBUG
Task:          ethernet-services : READ  WRITE    EXECUTE  DEBUG
```

show user group Command: Example

To view the user groups assigned to your user account, type the **show user group** command:

```
RP/0/RSP0/CPU0:router# show user group
root-system, cisco-support
```

show user all Command: Example

To view all user groups and task ID information for your account, type the **show user all** command:

```
P/0/RSP0/CPU0:router# show user all
Username: cisco
Groups: root-system, cisco-support
Authenticated using method local
User cisco has the following Task ID(s):

Task:          aaa : READ    WRITE    EXECUTE  DEBUG
Task:          acl  : READ    WRITE    EXECUTE  DEBUG
Task:          admin : READ    WRITE    EXECUTE  DEBUG
Task:          ancp : READ    WRITE    EXECUTE  DEBUG
Task:          atm  : READ    WRITE    EXECUTE  DEBUG
```

```

Task:      basic-services : READ   WRITE   EXECUTE   DEBUG
Task:      bcdl          : READ   WRITE   EXECUTE   DEBUG
Task:      bfd           : READ   WRITE   EXECUTE   DEBUG
Task:      bgp           : READ   WRITE   EXECUTE   DEBUG
Task:      boot          : READ   WRITE   EXECUTE   DEBUG
Task:      bundle        : READ   WRITE   EXECUTE   DEBUG
Task:      cdp           : READ   WRITE   EXECUTE   DEBUG
Task:      cef           : READ   WRITE   EXECUTE   DEBUG
Task:      cisco-support : READ   WRITE   EXECUTE   DEBUG (reserved)
Task:      config-mgmt   : READ   WRITE   EXECUTE   DEBUG
Task:      config-services : READ  WRITE   EXECUTE   DEBUG
Task:      crypto        : READ   WRITE   EXECUTE   DEBUG
Task:      diag          : READ   WRITE   EXECUTE   DEBUG
--More--

```

show aaa usergroup Command: Example

To view the rights assigned to a user group, type the **show aaa usergroup *group-name*** command:

```

RP/0/RSP0/CPU0:router# show aaa usergroup root-system
User group 'root-system'
  Inherits from task group 'root-system'

User group 'root-system' has the following combined set
of task IDs (including all inherited groups):
Task:      aaa          : READ   WRITE   EXECUTE   DEBUG
Task:      acl          : READ   WRITE   EXECUTE   DEBUG
Task:      admin        : READ   WRITE   EXECUTE   DEBUG
Task:      ancp         : READ   WRITE   EXECUTE   DEBUG
Task:      atm          : READ   WRITE   EXECUTE   DEBUG
Task:      basic-services : READ   WRITE   EXECUTE   DEBUG
Task:      bcdl         : READ   WRITE   EXECUTE   DEBUG
Task:      bfd          : READ   WRITE   EXECUTE   DEBUG
Task:      bgp          : READ   WRITE   EXECUTE   DEBUG
Task:      boot         : READ   WRITE   EXECUTE   DEBUG
Task:      bundle       : READ   WRITE   EXECUTE   DEBUG
Task:      cdp          : READ   WRITE   EXECUTE   DEBUG
Task:      cef          : READ   WRITE   EXECUTE   DEBUG
Task:      config-mgmt  : READ   WRITE   EXECUTE   DEBUG
Task:      config-services : READ  WRITE   EXECUTE   DEBUG
Task:      crypto       : READ   WRITE   EXECUTE   DEBUG
Task:      diag         : READ   WRITE   EXECUTE   DEBUG
Task:      drivers      : READ   WRITE   EXECUTE   DEBUG
--More--

```

Navigating Cisco IOS XR Software Command Modes

The Cisco IOS XR Software CLI has different command modes. Each mode provides access to a subset of commands used to configure, monitor, and manage the router. Access to a mode is determined by your user group. The following sections describe the navigation of the command modes:

- [Identifying the Command Mode in the CLI Prompt, page 3-11](#)
- [Common Command Modes, page 3-12](#)
- [Entering EXEC Commands from a Configuration Mode, page 3-14](#)
- [Command Mode Navigation Example, page 3-15](#)

Figure 3-1 shows the basic command mode navigation for the CLI. Only a sample of possible submodes is shown.

Figure 3-1 Example of Command Mode Navigation in Cisco IOS XR Software

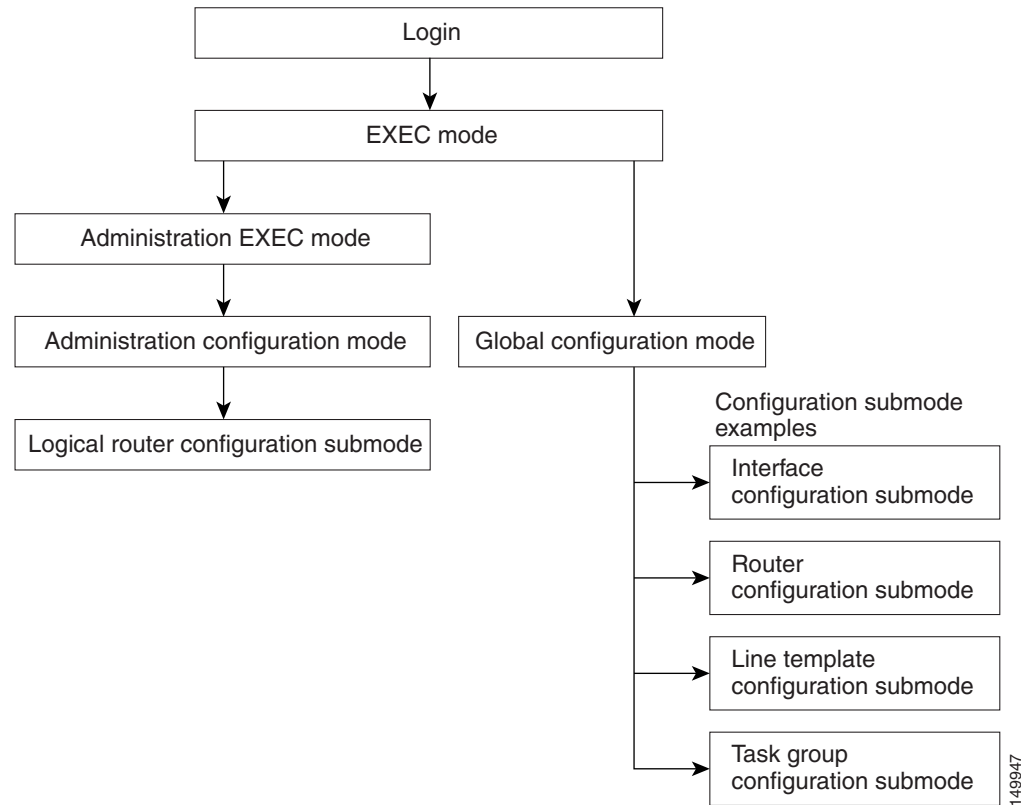

Identifying the Command Mode in the CLI Prompt

The command mode is identified in the CLI prompt after the router name.

When the router enters global configuration mode from the EXEC mode, the CLI prompt changes to include “(config)” after the router name:

```
RP/0/RSP0/CPU0:router# configure
RP/0/RSP0/CPU0:router(config)#
```

When the router enters interface configuration submode, the prompt changes to include “(config-if)” after the router name:

```
RP/0/RSP0/CPU0:router(config)# interface tunnel-te 2
RP/0/RSP0/CPU0:router(config-if)#
```

Common Command Modes

Table 3-4 summarizes the most common command modes of Cisco IOS XR Software and associated CLI prompts.

Table 3-4 Common Command Modes and CLI Prompts

Command Mode	Description
EXEC	<p>Logging in to an RP running the Cisco IOS XR Software automatically places the router in EXEC mode.</p> <p>Example:</p> <pre>RP/0/RSP0/CPU0:router#</pre> <p>EXEC mode enables a basic set of commands to display the operational state of an RP and the Cisco IOS XR Software. Most CLI commands in EXEC mode do not change the RP operation. The most common EXEC commands are show commands (to display RP configuration or operational data) and clear commands (to clear or reset RP counters).</p> <p>In EXEC mode, you can view the configuration of an RP but not the configuration of the system. The difference is that RSPs are defined in administration configuration mode, which is a submode of administration EXEC mode. RPs are configured in global configuration mode.</p> <p>Additional commands are available depending on the access privileges (user groups) assigned to your username. Minimal privileges also include a small set of EXEC commands for connecting to remote devices, changing terminal line settings on a temporary basis, and performing basic tests.</p>
Administration EXEC	<p>Administration EXEC mode is used to manage system resources. In administration EXEC mode, you can view the configuration of the system but not the configuration of an RP. The difference is that RPs are defined in administration configuration mode, which is a submode of administration EXEC mode. RPs are configured in global configuration mode.</p> <p>Administration EXEC mode is used primarily to view system-wide parameters, configure the administration plane over the control Ethernet, and configure the RP. These operations are available only to users with the required root level access.</p> <p>From EXEC mode, use the admin command to enter administration EXEC mode:</p> <pre>RP/0/RSP0/CPU0:router# admin RP/0/RSP0/CPU0:router(admin)#</pre>
administration configuration mode	<p>Administration configuration mode allows you to assign system resources to RSPs.</p> <p>From administration EXEC mode, use the configure command to enter administration configuration submode:</p> <pre>RP/0/RSP0/CPU0:router(admin)# configure RP/0/RSP0/CPU0:router(admin-config)#</pre>

Table 3-4 Common Command Modes and CLI Prompts (continued)

Command Mode	Description
Global configuration	<p>Global configuration mode is the starting point for RSP configuration. Commands entered in this mode affect the RSP as a whole, rather than just one protocol or interface. Global configuration mode is also used for entering configuration submodes to configure specific elements, such as interfaces or protocols.</p> <p>To enter global configuration mode, type the configure command at the EXEC command prompt:</p> <pre>RP/0/RSP0/CPU0:router# configure RP/0/RSP0/CPU0:router(config)#</pre> <p>Note The system prompt changes to “router(config)” to indicate that the router is now in global configuration mode.</p>
Configuration submodes	<p>From the global configuration mode you can enter more specific command modes. These are available based on your access privileges and include protocol-specific, platform-specific, and feature-specific configuration modes.</p> <p>In the following example, MPLS LDP configuration mode is entered from global configuration mode. The prompt for MPLS LDP configuration submode appears as config-ldp. The following command syntax is used for entering configuration MPLS LDP submode:</p> <pre>RP/0/RSP0/CPU0:router# configure RP/0/RSP0/CPU0:router(config)# mpls ldp RP/0/RSP0/CPU0:router(config-ldp)#</pre> <p>Note The availability of any particular mode depends on the router features and the access rights of the individual user. For example, a configuration mode for configuring access servers is not available on most routers.</p>
Interface configuration	<p>The interface configuration submode is used to select and configure a hardware interface. To enter interface configuration mode from global configuration mode, use an interface command. An interface configuration command always follows an interface global configuration command, which defines the interface type.</p> <pre>RP/0/RSP0/CPU0:router(config)# interface tunnel-te 2 RP/0/RSP0/CPU0:router(config-if)#</pre>
Router configuration	<p>The router configuration submode is used to select and configure a routing protocol, like OSPF, or IS-IS. The following command syntax is used for entering router configuration submode: router protocol [protocol_options]</p> <p>Replace <i>protocol</i> with the keyword for the protocol you want to configure. Replace <i>protocol_options</i> with any keywords and arguments required for that protocol.</p> <pre>RP/0/RSP0/CPU0:router(config)# router ospf 100 RP/0/RSP0/CPU0:router(config-ospf)#</pre>

Table 3-4 Common Command Modes and CLI Prompts (continued)

Command Mode	Description
Router submode configuration	<p>Router configuration submodes are accessed from router configuration mode. The following command syntax is used for entering router address family configuration submode:</p> <pre>RP/0/RSP0/CPU0:router(config)# router ospf 100 RP/0/RSP0/CPU0:router(config-ospf)# security ttl</pre> <p>For more information, see the following Cisco Systems documents:</p> <ul style="list-style-type: none"> • <i>Cisco ASR 9000 Series Aggregation Services Router Routing Configuration Guide</i> • <i>Cisco ASR 9000 Series Aggregation Services Router Routing Command Reference</i>
ROM Monitor (ROMMON) mode	<p>The ROM Monitor is a bootstrap program that initializes the hardware and boots the system when a router is powered on or reset. ROM Monitor mode is also known as “ROMMON,” which reflects the CLI prompt for the mode.</p> <pre>rommon B1></pre> <p>During normal operation, users do not interact with ROMMON. This mode is accessed only by manually interrupting the boot process and placing the system in ROMMON. Once in ROMMON, you can perform ROM Monitor tasks, including reinstallation of the Cisco IOS XR Software, password recovery, and other diagnostic tasks.</p> <p>The ROM Monitor CLI mode is accessible only from a terminal connected directly to the Console port of the primary RSP, a terminal-modem connection to the AUX port, or through a terminal server. See <i>Cisco ASR 9000 Series Aggregation Services Router ROM Monitor Guide</i> for information and instructions on using ROM Monitor mode.</p>

Entering EXEC Commands from a Configuration Mode

EXEC commands can be executed from any configuration mode by preceding the command with the **do** keyword. Executing EXEC commands from a configuration mode allows you to view the state of the system without exiting the configuration mode. For example:

```
RP/0/RSP0/CPU0:router(config)# do show version

Cisco IOS XR Software, Version 3.7.2.10I[FCI_DT_IMAGE]
Copyright (c) 2008 by Cisco Systems, Inc.

ROM: System Bootstrap, Version 0.63(20081010:215422) [ASR9K ROMMON],

router uptime is 1 week, 1 day, 11 hours, 47 minutes
System image file is "bootflash:disk0/asr9k-os-mpi-3.7.2.10I/mbiasr9k-rp.vm"

cisco ASR9K Series (MPC8641D) processor with 4194304K bytes of memory.
MPC8641D processor at 1333MHz, Revision 2.2

40 GigabitEthernet/IEEE 802.3 interface(s)
2 Ethernet/IEEE 802.3 interface(s)
12 TenGigabitEthernet/IEEE 802.3 interface(s)
219k bytes of non-volatile configuration memory.
975M bytes of compact flash card.
33994M bytes of hard disk.
1605616k bytes of disk0: (Sector size 512 bytes).
1605616k bytes of disk1: (Sector size 512 bytes).

Configuration register on node 0/RSP0/CPU0 is 0x2
```



```

Boot device on node 0/RSP0/CPU0 is disk0:
--More--

```

Command Mode Navigation Example

The following steps provide an example of command mode navigation:

Step 1 Start a session by logging in to the router and entering EXEC mode, as shown in the following example:

```
router is now available
```

Press Enter to get started.

```
User Access Verification
```

```

Username: asr9k
Password:<secret>
RP/0/RSP0/CPU0:router#

```

From EXEC mode you can issue EXEC commands or enter global configuration mode. Examples of EXEC commands are the **show** commands used to display system status and **clear** commands to clear counters or interfaces.

Step 2 Add a question mark at the end of the prompt, or after a command, to display the available options:

```

RP/0/RSP0/CPU0:router# show ?
  aaa                Show AAA configuration and operational data
  access-lists       Access lists
  access-lists       access lists
  adjacency           Adjacency information
  af-ea               AF-EA Platform details
  aliases             Display alias commands
  ancp                Access Node Control Protocol show commands
  app-obj             APP-OBJ Show Commands
  arm                 IP ARM information
  arp                 ARP show commands
  arp-gmp             ARP show commands
  asic-errors         ASIC error information
  atc                 Attractor Cache related
  attractor           Show commands for attractor process
  attribute           IM Attributes operations information
  auto-rp             Auto-RP Commands
  bcdl                Show Bulk Content DownLoader information
  bcm8705             Show trace data for the bcm8705 component
  bfd                 BFD information
  bgp                 BGP show commands
  bridgemib           show bridge-mib component
  bundle              Show information for bundles interfaces.
  calendar            Display the system calendar
  cdp                 CDP information
--More--

```



Note The commands available to you depend on the router mode and your user group assignments.

- Step 3** If you belong to a user group that has configuration privileges, you can place the router in the global configuration mode by entering the **configure** command:

```
RP/0/RSP0/CPU0:router# configure
RP/0/RSP0/CPU0:router(config)#
```

- Step 4** From global configuration mode, you can place the router in a configuration submode, such as interface configuration mode or a protocol-specific configuration mode.

```
RP/0/RSP0/CPU0:router# configure
RP/0/RSP0/CPU0:router(config)# mpls ldp
RP/0/RSP0/CPU0:router(config-ldp)#
```

In the following example, the router enters interface configuration mode and the user selects an MPLS Traffic Engineering Tunnel interface for configuration.

```
RP/0/RSP0/CPU0:router(config)# interface tunnel-te 2
RP/0/RSP0/CPU0:router(config-if)#
```

The command mode prompt changes from (config) to (config-if) and you can now enter configuration commands for the specified interface.

- Step 5** To exit interface configuration mode and return to global configuration mode, type the **exit** command. To return to EXEC mode, type the **end** command.

Managing Configuration Sessions

With the Cisco IOS XR Software, you cannot change the running (active) configuration directly. Enter configuration changes into an inactive target configuration. When the target configuration is ready, apply that configuration to the router with the **commit** command. This allows you to make, edit, and verify configuration changes before impacting the running state of the router.

Figure 3-2 shows the two-stage configuration process.

Figure 3-2 Two-Stage Configuration Process

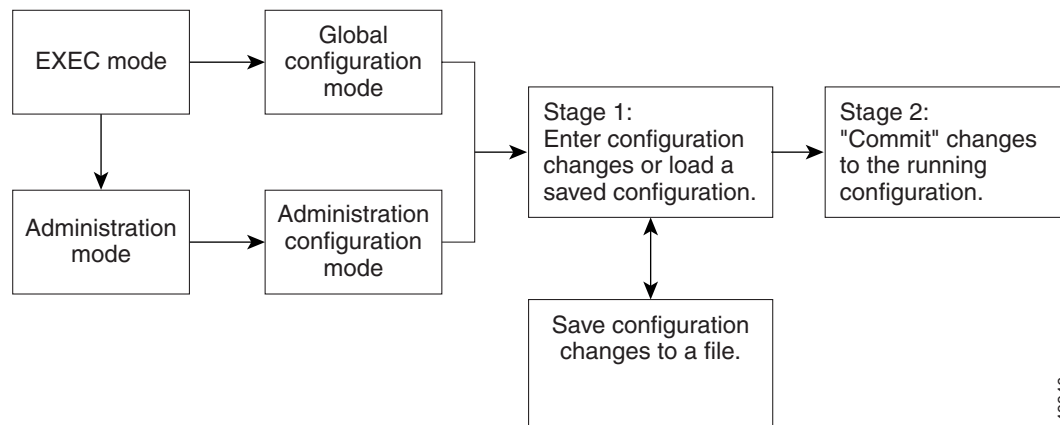

149946

Global configuration mode configures RSP-level features, such as routing protocols and interfaces. Administration configuration mode assigns hardware components to RSPs.

The following sections describe management options for configuration sessions:

- [Entering Configuration Changes, page 3-17](#)
- [Viewing Active Configuration Sessions, page 3-19](#)
- [Starting a Configuration Session, page 3-20](#)
- [Starting an Exclusive Configuration Session, page 3-21](#)
- [Viewing Configuration Details, page 3-21](#)
- [Saving the Target Configuration to a File, page 3-26](#)
- [Loading the Target Configuration from a File, page 3-26](#)
- [Loading an Alternative Configuration at System Startup, page 3-26](#)
- [Clearing All Changes to a Target Configuration, page 3-27](#)
- [Committing Changes to the Running Configuration, page 3-27](#)
- [Exiting a Configuration Submode, page 3-30](#)
- [Returning Directly to Configuration Mode from a Submode, page 3-30](#)
- [Configuring the RSP Hostname, page 3-31](#)
- [Specifying the Management Ethernet Interface Name in CLI Commands, page 3-32](#)
- [Viewing the Available Management Ethernet Interfaces, page 3-33](#)
- [Configuring the Management Ethernet Interface, page 3-33](#)

Entering Configuration Changes

You can make changes to a configuration and end up in one of two different modes, as follows:

1. Enter configuration changes.
2. The system prompts you to commit the changes.
3. The system saves the changes to the running configuration and leaves you in configuration mode or in EXEC mode.

To remain in CONFIG mode after you commit changes, perform the following procedure.

SUMMARY STEPS

1. **configure**
2. Enter configuration changes.
3. **end**
or
commit

DETAILED STEPS

	Command or Action	Purpose
Step 1	<code>configure</code> Example: RP/0/RSP0/CPU0:router# <code>configure</code>	Enters global configuration mode.
Step 2	Enter configuration changes.	Invokes the change you enter.
Step 3	<code>end</code> or <code>commit</code> Example: RP/0/RSP0/CPU0:router(your-config-mode)# <code>end</code> or RP/0/RSP0/CPU0:router(your-config-mode)# <code>commit</code>	Saves configuration changes. <ul style="list-style-type: none"> When you issue the end command, the system prompts you to commit changes: <pre>Uncommitted changes found, commit them before exiting(yes/no/cancel)? [cancel]:</pre> <ul style="list-style-type: none"> Entering yes saves configuration changes to the running configuration file, exits the configuration session, and returns the router to EXEC mode. Entering no exits the configuration session and returns the router to EXEC mode without committing the configuration changes. Entering cancel leaves the router in the current configuration session without exiting or committing the configuration changes. Use the commit command to save the configuration changes to the running configuration file and remain within the configuration session.

To make configuration changes and remain in CONFIG mode, perform the following procedure.

SUMMARY STEPS

- `configure`
- Enter configuration changes.
- `commit`
- `end`

DETAILED STEPS

	Command or Action	Purpose
Step 1	<code>configure</code> Example: RP/0/RSP0/CPU0:router# <code>configure</code>	Enters global configuration mode.
Step 2	Enter configuration changes.	Invokes the change you enter.

	Command or Action	Purpose
Step 3	commit Example: RP/0/RSP0/CPU0:router(your-config-mode)# commit	Saves configuration changes.
Step 4	end Example: RP/0/RSP0/CPU0:router(your-config-mode)# end	Saves configuration changes. <ul style="list-style-type: none"> When you issue the end command, the system prompts you to commit changes: <pre>Uncommitted changes found, commit them before exiting (yes/no/cancel)? [cancel]:</pre> <ul style="list-style-type: none"> Entering yes saves configuration changes to the running configuration file, exits the configuration session, and returns the router to EXEC mode. Entering no exits the configuration session and returns the router to EXEC mode without committing the configuration changes. Entering cancel leaves the router in the current configuration session without exiting or committing the configuration changes.

Viewing Active Configuration Sessions

Before you start a configuration session, check to see if there are other configuration sessions in progress. More than one user can open a target configuration session at a time, allowing multiple users to work on separate target configurations.

The procedure for viewing the active configuration sessions depends on the type of configuration session. For administration configuration sessions, that assign hardware components in RSPs, you must be in administration EXEC mode. For RSP configuration sessions, you must be in EXEC mode.

To view the active administration configuration sessions, connect to the router and type the **show configuration sessions** command in administration EXEC mode:

```
RP/0/RSP0/CPU0:router# admin
RP/0/RSP0/CPU0:router(admin)# show configuration sessions
```

To view active RSP configuration sessions, connect to the RSP and type the **show configuration sessions** command in EXEC mode:

```
RP/0/RSP0/CPU0:router# show configuration sessions
Current Configuration Session Line User Date Lock
00000041-006d60d3-00000000 vty0 merenenre Wed Dec 3 00:33:32 2008
```

If an asterisk (*) appears in the Lock column, the user is using an exclusive configuration session and you cannot start a configuration session until the session closes. For more information, see the “[Starting an Exclusive Configuration Session](#)” section on page 3-21.



Note

Configuration sessions for administration configuration and each RSP are managed independently. For example, if a user locks the administration configuration, you can still configure an RSP if other users have not locked a configuration session for that RSP.

Starting a Configuration Session

When you place the router in global configuration or administration configuration mode using the **configure** command, a new target configuration session is created. The target configuration allows you to enter, review, and verify configuration changes without impacting the running configuration.



Note

The target configuration is not a copy of the running configuration. It has only the configuration commands entered during the target configuration session.

While in configuration mode, you can enter all Cisco IOS XR Software commands supported in that configuration mode. Each command is added to the target configuration. You can view the target configuration by entering the **show configuration** command in configuration mode. The target configuration is not applied until you type the **commit** command, as described in the “[Committing Changes to the Running Configuration](#)” section on page 3-27.

You can save target configurations to disk as nonactive configuration files. These saved files can be loaded, further modified, and committed at a later time. For more information, see the “[Saving the Target Configuration to a File](#)” section on page 3-26.

Examples

The following examples show how to manage configuration sessions:

- [Simple RSP Configuration: Example, page 3-20](#)
- [Simple Administration Configuration Session: Example, page 3-20](#)

Simple RSP Configuration: Example

This example shows a simple owner RSP configuration session in which the target configuration is created and previewed in global configuration mode:

```
RP/0/RSP0/CPU0:router # configure
RP/0/RSP0/CPU0:router(config)# interface tunnel-te 2
RP/0/RSP0/CPU0:router(config-if)# show configuration
Building configuration...
interface tunnel-te2
  description faq
!
end
```

Simple Administration Configuration Session: Example

The following example shows a simple administration configuration session in which the target configuration is created and previewed in administration configuration mode:

```
RP/0/RSP0/CPU0:router# admin
RP/0/RSP0/CPU0:router(admin)# configure
RP/0/RSP0/CPU0:router(admin-config)# sdr test
RP/0/RSP0/CPU0:router(admin-config-sdr:test)# location 0/1/CPU0
RP/0/RSP0/CPU0:router(admin-config-sdr:test)# show configuration

Building configuration...
sdr test
  location 0/1/CPU0
!
```

```
end
```

Starting an Exclusive Configuration Session

An exclusive configuration session allows you to configure the administration configuration or an RSP and lock out all users from committing configuration changes until you are done. Other users can still create and modify a target configuration, but they cannot commit those changes to the running configuration until you exit.

During regular configuration sessions, the running configuration is locked whenever a commit operation is being performed. This automatic locking ensures each commit operation is completed before the next one begins. Other users receive an error message if they attempt to commit a target configuration while another commit operation is under way.

To start an exclusive configuration session for an RSP, connect to that RSP and type the **configure exclusive** command:

```
RP/0/RSP0/CPU0:router# configure exclusive  
RP/0/RSP0/CPU0:router(config)#
```



Note

If the configuration is already locked by another user, the **configure exclusive** command fails. To view locked and unlocked configuration sessions, see the [“Viewing Active Configuration Sessions”](#) section on page 3-19.

To start an exclusive configuration session for the administration configuration, connect to the RSP and type the **configure exclusive** command in administration EXEC mode:

```
RP/0/RSP0/CPU0:router# admin  
RP/0/RSP0/CPU0:router(admin)# configure exclusive  
RP/0/RSP0/CPU0:router(admin-config)#
```

The running configuration is unlocked when the user who started the exclusive configuration session exits the configuration mode, as described in the [“Ending a Configuration Session”](#) section on page 3-31.

Viewing Configuration Details

The following sections describe the different ways to view information about your configuration:

- [Viewing the Running Configuration, page 3-21](#)
- [Viewing a Sanitized Version of the Running Configuration, page 3-22](#)
- [Viewing the Target Configuration, page 3-23](#)
- [Viewing a Combined Target and Running Configuration, page 3-24](#)
- [Viewing Configuration Error Messages and Descriptions, page 3-25](#)
- [Viewing Configuration Error Messages Without Descriptions, page 3-25](#)
- [Viewing Configuration Error Messages Produced While Loading a Configuration, page 3-25](#)

Viewing the Running Configuration

The running configuration is the committed configuration that defines the router operations, and it is divided into the administration configuration and an RSP configuration for each RSP. The portion of the running configuration that you can view depends on the current CLI mode and RSP connection.

In EXEC and global configuration mode, you can view the RSP configuration for the RSP to which you are connected. When you are connected to the RSP and operating in administration EXEC and administration configuration mode, you can view the administration configuration, which includes hardware assignments for RSPs.

To display the RSP portion of the running configuration, connect to the appropriate RSP and type the **show running-config** command in EXEC or global configuration mode, as shown in the following example:

```
RP/0/RSP0/CPU0:router(config)# show running-config
Building configuration...
!! Last configuration change at Tue Dec  2 20:29:51 2008 by cisco
!
hostname router
clock timezone PST 8
clock summer-time DST recurring 2 sunday march 02:00 first sunday november 02:00
logging console informational
telnet vrf default ipv4 server max-servers no-limit
domain lookup disable
explicit-path name GE_Path_to_P19
  index 1 next-address strict ipv4 unicast 10.114.4.44
  index 2 next-address strict ipv4 unicast 10.114.4.11
  index 3 next-address strict ipv4 unicast 10.119.4.11
  index 4 next-address strict ipv4 unicast 10.119.4.19
  index 5 next-address strict ipv4 unicast 10.19.19.19
!
explicit-path name 10GE_Path_to_P19
  index 1 next-address strict ipv4 unicast 10.114.8.44
  index 2 next-address strict ipv4 unicast 10.114.8.11
  index 3 next-address strict ipv4 unicast 10.119.8.11
  index 4 next-address strict ipv4 unicast 10.119.8.19
  index 5 next-address strict ipv4 unicast 10.19.19.19
!
line console
```

To display the administration portion of the running configuration, connect to the RSP and type the **show running-config** command in administration EXEC or administration configuration mode, as shown in the following example:

```
RP/0/RSP0/CPU0:router(admin)# show running-config
Building configuration...
username cisco
  group root-system
  group cisco-support
  secret 5 $1$2dx.$/AGxtYJYRWhajo4INlAVa0
--More--
```

Viewing a Sanitized Version of the Running Configuration

A sanitized running configuration report displays the contents of the running configuration without installation specific parameters. Some configuration details, such as IP addresses, are replaced with different addresses. The sanitized configuration can be used to share a configuration without exposing the configuration details.

In EXEC and global configuration mode, you can view the sanitized RSP configuration for the RSP to which you are connected. When you are connected to the RSP and operating in administration EXEC and administration configuration mode, you can view the sanitized administration configuration, which includes hardware assignments for RSPs.

To display the sanitized RSP portion of the running configuration, type the **show running-config sanitized** command in EXEC or global configuration mode, as shown in the following example:

```
RP/0/RSP0/CPU0:router(config)#show running-config sanitized
Building configuration...
!! Last configuration change at Tue Dec  2 20:29:51 2008 by <removed>
!
hostname <removed>
clock timezone <removed> 8
clock summer-time <removed> recurring 2 sunday march 02:00 first sunday november 02:00
logging console informational
telnet vrf <removed> ipv4 server max-servers no-limit
domain lookup disable
explicit-path name <removed>
  index 1 next-address strict ipv4 unicast 10.0.0.0
  index 2 next-address strict ipv4 unicast 10.0.0.0
  index 3 next-address strict ipv4 unicast 10.0.0.0
  index 4 next-address strict ipv4 unicast 10.0.0.0
  index 5 next-address strict ipv4 unicast 10.0.0.0
!
explicit-path name <removed>
  index 1 next-address strict ipv4 unicast 10.0.0.0
  index 2 next-address strict ipv4 unicast 10.0.0.0
  index 3 next-address strict ipv4 unicast 10.0.0.0
  index 4 next-address strict ipv4 unicast 10.0.0.0
  index 5 next-address strict ipv4 unicast 10.0.0.0
!
line console
--More--
```

To display the sanitized administration portion of the running configuration, connect to the RSP and type the **show running-config sanitized** command in administration EXEC or administration configuration mode, as shown in the following example:

```
RP/0/RSP0/CPU0:router(admin)# show running-config sanitized
Building configuration...
sdr <removed>
  location 0/1/* primary
!
username <removed>
  secret 5 <removed>
  group root-system
!
end
```

Viewing the Target Configuration

The target configuration includes the configuration changes that have been entered but not yet committed. These changes are not yet part of the running configuration.

You can view the target configuration in global configuration and administration configuration modes. You cannot view the target configuration in EXEC modes because the target configuration must be committed or abandoned before returning to EXEC or administration EXEC mode.

To display the target configuration changes you have entered for an RSP, type the **show configuration** command in global configuration mode or in any submode, as shown in the following example:

```
RP/0/RSP0/CPU0:router(config-if)# show configuration
Building configuration...
interface tunnel-te2
  description faq
!
end
```

To display the target administration configuration changes you have entered, type the **show configuration** command in administration configuration mode or in any submode, as shown in the following example:

```
RP/0/RSP0/CPU0:router(admin-config-sdr:test)# show configuration
Building configuration...
sdr test
  location 0/1/SP
!
end
```

Viewing a Combined Target and Running Configuration

Although the target and running configurations remain separate until the target configuration is committed, you can preview the combined target and running configuration without committing the changes. The combined configuration shows what the new running configuration will look like after the changes from the target configuration are committed. It does not represent the actual running configuration.

You can preview the combined configuration in global configuration and administration configuration modes. You cannot preview the combined configuration in EXEC modes because the target configuration must be committed or abandoned before returning to EXEC or administration EXEC mode.

To display the combined target and running configuration, type the **show configuration merge** command in any configuration mode.



Note

The **merge** option does not appear in command help until the target configuration contains at least one configuration change.

The following example shows how to display the active RSP configuration (**show running-config**), configure an interface, and display the “merged” configuration:

```
RP/0/RSP0/CPU0:router(config-if)# show configuration merge
Building configuration...
!! Last configuration change at Tue Dec  2 20:29:51 2008 by cisco
!
hostname router
clock timezone PST 8
clock summer-time DST recurring 2 sunday march 02:00 first sunday november 02:00
logging console informational
telnet vrf default ipv4 server max-servers no-limit
domain lookup disable
explicit-path name GE_Path_to_P19
  index 1 next-address strict ipv4 unicast 10.114.4.44
  index 2 next-address strict ipv4 unicast 10.114.4.11
  index 3 next-address strict ipv4 unicast 10.119.4.11
  index 4 next-address strict ipv4 unicast 10.119.4.19
  index 5 next-address strict ipv4 unicast 10.19.19.19
```

```

!
explicit-path name 10GE_Path_to_P19
 index 1 next-address strict ipv4 unicast 10.114.8.44
 index 2 next-address strict ipv4 unicast 10.114.8.11
 index 3 next-address strict ipv4 unicast 10.119.8.11
 index 4 next-address strict ipv4 unicast 10.119.8.19
 index 5 next-address strict ipv4 unicast 10.19.19.19
!
line console

```

Viewing Configuration Error Messages and Descriptions

Configuration changes are automatically verified during the commit operation, and a message appears if one or more configuration entries fail. To display an error message and description for a failed configuration, type the **show configuration failed** command.



Note

You can view configuration errors only during the current configuration session. If you exit configuration mode after the commit operation, the configuration error information is lost.

In the following example, an error is introduced in global configuration mode and the error information appears after the commit operation fails:

```

RP/0/RSP0/CPU0:router# configure
RP/0/RSP0/CPU0:router(config)# taskgroup alr
RP/0/RSP0/CPU0:router(config-tg)# description this is a test of an invalid taskgroup
RP/0/RSP0/CPU0:router(config-tg)# commit
% Failed to commit one or more configuration items. Please use 'show configuration failed'
to view the errors
RP/0/RSP0/CPU0:router(config-tg)# show configuration failed
!! CONFIGURATION FAILED DUE TO SEMANTIC ERRORS
taskgroup alr
!!% Usergroup/Taskgroup names cannot be taskid names

```

Viewing Configuration Error Messages Without Descriptions

Configuration changes are automatically verified during the commit operation, and a message appears if one or more configuration entries fail. To display only the error message (without a description) for a failed configuration, type the **show configuration failed noerror** command, as shown in the following example:

```

RP/0/RSP0/CPU0:router(config-tg)# show configuration failed noerror
!! CONFIGURATION FAILED DUE TO SEMANTIC ERRORS
taskgroup alr
!

```



Note

You can view configuration errors only during the current configuration session. If you exit configuration mode after the commit operation, the configuration error information is lost.

Viewing Configuration Error Messages Produced While Loading a Configuration

To display any syntax errors found in a configuration loaded with the **load** command, type the **show configuration failed load** command.

Saving the Target Configuration to a File

Target configurations can be saved to a separate file without committing them to the running configuration. Target configuration files can then be loaded at a later time and further modified or committed.

To save the configuration changes in the target configuration to a file, type the **save configuration device:** command. Replace the *device* argument with the name of the device on which you want to store the file (for example, disk0). After you enter this command, the router prompts you to enter a filename. If you enter only a filename, the file is stored in the root directory of the device. To store the file in a directory, type the directory path and filename when prompted. We recommend that you specify the `cfg` file extension for easy identification. This suffix is not required, but it can help locate target configuration files. Example: `myconfig.cfg`

The following example shows a target configuration file saved to the `usr/cisco` directory of `disk0`:

```
RP/0/RSP1/CPU0:router(admin-config)# save configuration disk0:

Destination file name (control-c to abort): [/running-config]?usr/cisco/test.cfg
Building configuration.
1 lines built in 1 second
[OK]
```



Note

You can also save a configuration to a file using the **show configuration | file filename** command.

Loading the Target Configuration from a File

To populate the target configuration with the contents of a previously saved configuration file, go to global configuration or administration configuration mode and type the **load filename** command. Consider the following when entering the *filename* argument:

- The *filename* argument specifies the configuration file to be loaded into the target configuration.
- If the full path of the file is not specified, the router attempts to load the file from the root directory on the device.

The following example shows a target configuration file loaded into the current configuration session. The current configuration session is populated with the contents of the file:

```
RP/0/RSP1/CPU0:router(config)# load disk0:/usr/cisco/test.cfg

Loading.
77 bytes parsed in 1 sec (76)bytes/sec
```

Loading an Alternative Configuration at System Startup

When a router is reset or powered on, the last running configuration is loaded and used to operate the router.

You can load an alternative configuration during system boot. See *Cisco ASR 9000 Series Aggregation Services Router ROM Monitor Guide* for information and instructions on this process.

Clearing All Changes to a Target Configuration

To clear changes made to the target configuration without terminating the configuration session, type the **clear** command in global configuration mode or administration configuration mode. This command deletes any configuration changes that have not been committed.

In the following example, the user configures an interface but does not commit it. After reviewing the changes to the target configuration with the **show configuration** command, the user decides to remove the changes and start over by entering the **clear** command:

```
RP/0/RSP0/CPU0:router# configure
RP/0/RSP0/CPU0:router(config)# interface Gi 0/3/0/1
RP/0/RSP0/CPU0:router(config-if)# description this is my interface
RP/0/RSP0/CPU0:router(config-if)# ipv4 address 10.1.1.1 255.0.0.0
RP/0/RSP0/CPU0:router(config-if)# shutdown
RP/0/RSP0/CPU0:router(config-if)# exit

RP/0/RSP0/CPU0:router(config)# show configuration

Building configuration...
interface Gi0/3/0/1
  description this is my interface
  ipv4 address 10.1.1.1 255.0.0.0
  shutdown
end

RP/0/RSP0/CPU0:router(config)# clear
RP/0/RSP0/CPU0:router(config)# show configuration
Building configuration...
end
```

Committing Changes to the Running Configuration

The changes in the target configuration do not become part of the running configuration until you type the **commit** command. When you commit a target configuration, you can use the **commit** command to do either of the following:

- Merge the target configuration with the running configuration to create a new running configuration.
- Replace the running configuration with the target configuration.

**Note**

If you try to end a configuration session without saving your changes to the running configuration with the **commit** command, you are prompted to save the changes. See the [“Ending a Configuration Session” section on page 3-31](#) for more information.

To commit target configuration changes to the running configuration, type the **commit** command by itself or with one or more of the options described in [Table 3-5](#).

Table 3-5 Commit Command Options

Command	Description
commit	(Default) Merges the target configuration with the running configuration and commits changes only if all changes in the target configuration pass the semantic verification process. If any semantic errors are found, none of the configuration changes takes effect.
commit best-effort	Merges the target configuration with the running configuration and commits only valid changes (best effort). Some configuration changes might fail due to semantic errors.
commit comment <i>line</i>	<p>(Optional) Assigns a comment to a commit.</p> <ul style="list-style-type: none"> This text comment appears in the commit entry displayed with the show configuration commit list [detail] command. The <i>line</i> argument is the text for the optional comment or label. The comment option must appear at the end of the command line. If multiple options are entered, all text after the comment option is treated as a comment.
commit confirmed <i>seconds</i>	<p>(Optional) Commits the configuration in global configuration mode on a trial basis for a minimum of 30 seconds and a maximum of 300 seconds (5 minutes).</p> <ul style="list-style-type: none"> During the trial configuration, enter commit to confirm the configuration. If you do not type the commit command, the router reverts to the previous configuration when the trial time period expires. The confirmed option is not available in administration configuration mode.
commit label <i>line</i>	<p>(Optional) Assigns a meaningful label. This label appears in the output for the show configuration commit list [detail] command instead of the numeric label.</p> <ul style="list-style-type: none"> The <i>line</i> argument is the text for the optional comment or label.
commit force	<p>(Optional) Merges the target configuration with the running configuration and allows a configuration commit in low-memory conditions.</p> <p>A low-memory warning occurs when a user attempts to commit a target configuration that exceeds the default capacity of the router.</p> <p>The recommended resolution to such a warning is to remove configurations using the no commands.</p> <div style="border: 1px solid black; padding: 5px; margin-top: 10px;">  <p>Caution The force option can cause the router to experience severe problems if low-memory conditions occur. The force option should be used only to remove configurations.</p> </div>
commit replace	(Optional) Replaces the contents of the running configuration with the target configuration.

Examples

The following examples illustrate how to commit a configuration:

- [Committing a Configuration from Global Configuration Mode: Example, page 3-29](#)
- [Committing a Configuration from Administration Configuration Mode: Example, page 3-29](#)

Committing a Configuration from Global Configuration Mode: Example

In the following example, the default **commit** command is entered in global configuration mode:

```
RP/0/RSP0/CPU0:router# configure
RP/0/RSP0/CPU0:router(config)# interface Gi 0/0/0/2
RP/0/RSP0/CPU0:router(config-if)# description faq
RP/0/RSP0/CPU0:router(config-if)# ipv4 address 10.1.1.1 255.0.0.0
RP/0/RSP0/CPU0:router(config-if)# commit
```

```
RP/0/0/0:Aug 6 09:26:17.781 : %LIBTARCFG-6-COMMIT Configuration committed by user
'cisco'. Use 'show configuration commit changes 1000000124' to view the changes.
```



Note

The preceding message is stored in the log and displays only if logging is configured to display on screen.

Committing a Configuration from Administration Configuration Mode: Example

In the next example, the **commit** command is entered with the **label** and **comment** options in administration configuration mode:

```
RP/0/RSP0/CPU0:router# admin
RP/0/RSP0/CPU0:router(admin)# configure
RP/0/RSP0/CPU0:router(admin-config)# sdr test
RP/0/RSP0/CPU0:router(admin-config-sdr:test)# location 0/1/* primary
RP/0/RSP0/CPU0:router(admin-config-sdr:test)# commit label test comment This is a test
RP/0/RSP0/CPU0:router(admin-config)# show configuration commit list detail
```

```
1) CommitId: 2000000018                Label: test
   UserId:   user1                     Line: vty1
   Client:   CLI                        Time: 23:45:40 UTC Wed Dec 02 2008
   Comment:  This is a test
```



Note

Configuration files are stored on the same flash disk as the boot image. Access these configurations only through the CLI commands for configuration management, history, and rollback. Direct modification or deletion of these files can result in lost router configurations.

Reloading a Failed Configuration

If the router displays a configuration failure message when you attempt to commit a configuration change, the configuration changes are not lost. While you remain in global configuration mode or administration configuration mode, you can load the configuration changes into the target configuration, correct the errors, and commit the changes.

To load a failed configuration, go to global configuration or administration configuration mode and type the **load configuration failed commit** command, as shown in the following example:

```
RP/0/0/CPU0:router(config)# load configuration failed commit
RP/0/0/CPU0:router(config)# show configuration
Building configuration...
taskgroup alr
!
end
```

In the preceding example, the **show configuration** command displays the target configuration, which includes the failed configuration.

**Note**

The failed configuration is discarded if you exit global configuration mode or administration configuration mode without recovering the configuration. After recovery, correct and commit the configuration or save it to a file to avoid losing it.

Exiting a Configuration Submode

When you have finished configuration changes in a configuration submode, such as the interface or RSP configuration submodes, you can return to return to the previous configuration mode and continue making configuration changes. To exit a configuration submode, type the **exit** command, as shown in the following example:

```
RP/0/RSP0/CPU0:router# configure
RP/0/RSP0/CPU0:router(config)# interface Gi 0/3/0/1
RP/0/RSP0/CPU0:router(config-if)# description this is my interface
RP/0/RSP0/CPU0:router(config-if)# ipv4 address 10.1.1.1 255.0.0.0
RP/0/RSP0/CPU0:router(config-if)# exit
RP/0/RSP0/CPU0:router(config)#
```

**Note**

If you use the **exit** command to exit global configuration or administration configuration mode, the router prompts you to save changes, discard changes, or cancel the action, as described in the next section.

Returning Directly to Configuration Mode from a Submode

When you have finished configuration changes in a configuration submode, such as the interface or RSP configuration submodes, you can skip all intermediate submodes and return to the top-level configuration mode and continue making configuration changes. To return to configuration mode, type the **root** command, as shown in the following example:

```
RP/0/RSP0/CPU0:router# configure
RP/0/RSP0/CPU0:router(config)# router static
RP/0/RSP0/CPU0:router(config-static)# address-family ipv4 unicast
RP/0/RSP0/CPU0:router(config-static-afi)# root
RP/0/RSP0/CPU0:router(config)#
```

Ending a Configuration Session

You can use any of the following methods to end a configuration session:

- Type the **exit** command in global configuration or administration configuration mode.
- Type the **end** command in any configuration mode or submode
- Press Ctrl-Z.



Note

If you type the **exit** command in a configuration submode, the command returns you to the parent configuration level.

If you end a configuration session without committing the configuration changes, the router prompts you to save changes, discard changes, or cancel the action, as shown in the following example:

```
RP/0/RSP0/CPU0:router(config-if)# end
```

```
Uncommitted changes found, commit them before exiting(yes/no/cancel)? [cancel]:
```

Respond to the prompt by entering one of the following options:

- **yes**—Commit the configuration changes and exit configuration mode.
- **no**—Exit configuration mode without committing the configuration changes.
- **cancel**—Remain in configuration mode without committing the configuration changes.



Note

In EXEC mode, the **exit** command logs the user out of the system.

Aborting a Configuration Session

When you abort a configuration session, any changes are discarded and the configuration session ends. No warning is given before the configuration changes are deleted.

In global configuration mode, the **abort** command discards configuration changes and returns to EXEC mode. In administration configuration mode, the **abort** command discards configuration changes and returns to administration EXEC mode. To abort a configuration session, type the **abort** command, as shown in the following example:

```
RP/0/RSP0/CPU0:router# configure
RP/0/RSP0/CPU0:router(config)# hostname host1
RP/0/RSP0/CPU0:router(config)# interface Gi 0/2/0/2
RP/0/RSP0/CPU0:router(config-if)# description this is my interface
RP/0/RSP0/CPU0:router(config-if)# ipv4 address 10.1.1.1 255.0.0.0
RP/0/RSP0/CPU0:router(config-if)# shutdown
RP/0/RSP0/CPU0:router(config-if)# abort
RP/0/RSP0/CPU0:router#
```

Configuring the RSP Hostname

The hostname identifies an RSP on the network. Although devices can be uniquely identified by their Layer 2 and Layer 3 addresses (such as an IP address), it is often simpler to remember network devices by an alphanumeric “hostname.” This name is used in the CLI prompt and default configuration filenames and to identify the RSP on the network.

To configure the hostname, type the **hostname** command with the RSP name as shown in the following example:

```
RP/0/RSP0/CPU0:router# configure
RP/0/RSP0/CPU0:router(config)# hostname SDR_SJ
RP/0/RSP0/CPU0:router(config)# commit

RP/0/RSP0/CPU0:Apr  7 00:07:33.246 : config[65669]: %LIBTARCFG-6-COMMIT : Configuration
committed by user 'user_a'. Use 'show configuration commit changes 1000000067' to view
the changes.
RP/0/RSP0/CPU0:RP_SJ(config)#
```

The preceding example sets the RSP name to RP_SJ.



Note

No blanks or spaces are permitted as part of a name. Do not expect case to be preserved. Uppercase and lowercase characters look the same to many Internet software applications. It may seem appropriate to capitalize a name the same way you might if you were writing, but conventions dictate that computer names appear all lowercase. For more information, see RFC 1178, *Choosing a Name for Your Computer*.

Configuring the Management Ethernet Interface

The Management Ethernet interface on the RSPs is used to connect the router to a network for remote management using a Telnet client, the Simple Network Management Protocol (SNMP), or other management agents. The following sections provide information on the Management Ethernet interface:

- [Specifying the Management Ethernet Interface Name in CLI Commands, page 3-32](#)
- [Viewing the Available Management Ethernet Interfaces, page 3-33](#)
- [Configuring the Management Ethernet Interface, page 3-33](#)

Specifying the Management Ethernet Interface Name in CLI Commands

Before you can configure the Management Ethernet interface, you must know the Management Ethernet interface name, which is defined using the following syntax: *typerack/slot/module/port*. [Table 3-6](#) describes the Management Ethernet interface name syntax.

Table 3-6 Management Ethernet Interface Name Syntax Description

Syntax Components	Description
<i>type</i>	Interface <i>type</i> for a Management Ethernet port is “MgmtEth.”
<i>rack</i>	Chassis number of the rack. In a single-shelf system, the <i>rack</i> is always “0.”
<i>slot</i>	Physical slot of the RSP on which the interface is located. For a Cisco ASR 9000 Series router, the RSP <i>slot</i> is “RSP0” or “RSP1.”
<i>module</i>	On an RSP, the <i>module</i> is “CPU0.” RSPs have two processors, so the <i>module</i> is either “CPU0” and “CPU1.”
<i>port</i>	On a Cisco ASR 9000 Series router, one Ethernet port labeled MGMT ETH exists on each RSP. Specify 0 for the MGMT ETH interface on an RSP.

Table 3-7 provides examples of Management Ethernet interface names for a single-shelf system. The Management Ethernet interfaces are listed with the prefix Mg in the Intf Name column.

Table 3-7 Management Ethernet Interface Names

Management Interface Name	Example
MgmtEth0/RSP0/CPU0/0	router(config)# interface MgmtEth0/RSP0/CPU0/0
MgmtEth0/RSP0/CPU0/1	router(config)# interface MgmtEth0/RSP0/CPU0/1
MgmtEth0/RSP1/CPU0/0	router(config)# interface MgmtEth0/RSP1/CPU0/0
MgmtEth0/RSP1/CPU0/1	router(config)# interface MgmtEth0/RSP1/CPU0/1

Viewing the Available Management Ethernet Interfaces

To display the router interfaces, type the **show interfaces brief** command in EXEC mode as follows:

```
RP/0/RSP0/CPU0:router#show interfaces brief
```

Intf Name	Intf State	LineP State	Encap Type	MTU (byte)	BW (Kbps)
Lo0	up	up	Loopback	1514	Unknown
Nu0	up	up	Null	1500	Unknown
tt44190	up	up	TUNNEL	1500	100000
tt44194	up	up	TUNNEL	1500	100000
Mg0/RSP0/CPU0/0	up	up	ARPA	1514	100000
Mg0/RSP0/CPU0/1	admin-down	admin-down	ARPA	1514	10000
Gi0/1/0/0	admin-down	admin-down	ARPA	1514	1000000
Gi0/1/0/1	admin-down	admin-down	ARPA	1514	1000000
Gi0/1/0/2	up	up	ARPA	9014	1000000
Gi0/1/0/3	up	up	802.1Q VLAN	9014	1000000
Gi0/1/0/3.185	up	up	802.1Q VLAN	9022	1000000
Gi0/1/0/3.189	up	up	802.1Q VLAN	9022	1000000
Gi0/1/0/3.215	up	up	802.1Q VLAN	9022	1000000
Gi0/1/0/4	admin-down	admin-down	ARPA	1514	1000000
Gi0/1/0/5	admin-down	admin-down	ARPA	1514	1000000
Gi0/1/0/6	admin-down	admin-down	ARPA	1514	1000000
Gi0/1/0/7	up	up	802.1Q VLAN	9014	1000000
Gi0/1/0/7.185	up	up	802.1Q VLAN	9022	1000000
Gi0/1/0/7.187	up	up	802.1Q VLAN	9014	1000000

--More--

Configuring the Management Ethernet Interface

To use the Management Ethernet interface for system management and remote communication, you must configure an IP address and a subnet mask for the interface. If you want the interface to communicate with devices on other networks (such as remote management stations or TFTP servers), you need to configure a default route for the router.



Tip

For information on additional configuration options for the Management Ethernet interface, see *Cisco ASR 9000 Series Aggregation Services Router Interface and Hardware Component Configuration Guide*.

Prerequisites

To configure the Ethernet Management port for network communications, you must type the interface network addresses and subnet mask. Consult your network administrator or system planner for this information.

SUMMARY STEPS

1. **configure**
2. **interface MgmtEthrack/slot/CPU0/port**
3. **ipv4 address** *ipv4-address subnet-mask*
4. **no shutdown**
5. **exit**
6. **router static address-family ipv4 unicast** *0.0.0.0/0 default-gateway*
7. **commit**
8. **end**
9. **show interfaces MgmtEthrack/slot/CPU0/port**

DETAILED STEPS

	Command or Action	Purpose
Step 1	configure Example: RP/0/RSP0/CPU0:router# configure	Enters global configuration mode.
Step 2	interface MgmtEthrack/slot/CPU0/port Example: RP/0/RSP0/CPU0:RO-C(config)# interface mgmtEth0/RSP0/CPU0/0	Enters interface configuration mode and specifies the Management Ethernet interface of the primary RSP. See Table 3-6 for command parameters.
Step 3	ipv4 address <i>ipv4-address subnet-mask</i> Example: RP/0/RSP0/CPU0:RO-C(config-if)# ipv4 address 1.1.1.1 255.255.255.255	Assigns an IP address and subnet mask to the interface.
Step 4	no shutdown Example: RP/0/RSP0/CPU0:router(config-if)# no shutdown	Enables the interface to carry traffic.
Step 5	exit Example RP/0/RSP0/CPU0:RO-C(config)# sh config Building configuration... interface MgmtEth0/RSP0/CPU0/0 ipv4 address 1.1.1.1 255.255.255.255 ! end	Exits the Management Ethernet interface configuration mode.

	Command or Action	Purpose
Step 6	<pre>router static address-family ipv4 unicast 0.0.0.0/0 default-gateway</pre> <p>Example: RP/0/RSP0/CPU0:router(config-static)# address-family ipv4 unicast</p>	Establishes a static route.
Step 7	<pre>commit</pre> <p>Example: RP/0/RSP0/CPU0:RO-C(config)# commit</p>	Commits the target configuration to the running configuration.
Step 8	<pre>end</pre> <p>Example:</p>	<p>Saves configuration changes.</p> <ul style="list-style-type: none"> When you issue the end command, the system prompts you to commit changes: Uncommitted changes found, commit them before exiting (yes/no/cancel)? [cancel]: Entering yes saves configuration changes to the running configuration file, exits the configuration session, and returns the router to EXEC mode. Entering no exits the configuration session and returns the router to EXEC mode without committing the configuration changes. Entering cancel leaves the router in the current configuration session without exiting or committing the configuration changes.
Step 9	<pre>show interfaces MgmtEth<rack/slot/>CPU0/port</pre> <p>Example: RP/0/RSP0/CPU0:router(config)# interface MgmtEth 0/RP0/CPU0/0</p>	Displays statistics for the management interfaces configured on the router.

Examples

In the following example, the Management Ethernet interface on the RSP in slot RSP1 is configured with an IP address:

```
RP/0/RSP0/CPU0:router# configure
RP/0/RSP0/CPU0:router(config)# interface MgmtEth0/RSP1/CPU0/0
RP/0/RSP0/CPU0:router(config-if)# ipv4 address 10.1.1.1 255.255.255.0
RP/0/RSP0/CPU0:router(config-if)# no shutdown
RP/0/RSP0/CPU0:router(config-if)# commit
RP/0/RSP0/CPU0:router(config-if)# end
RP/0/RSP0/CPU0:router#
RP/0/RSP0/CPU0:router# show interfaces mgmtEth 0/RSP0/CPU0/0

MgmtEth0/RSP0/CPU0/0 is up, line protocol is up
  Hardware is Management Ethernet, address is 0011.93ef.e8ea (bia 0011.93ef.e8e)
  Description: Connected to Lab LAN
  Internet address is 10.1.1.1/24
  MTU 1514 bytes, BW 100000 Kbit
    reliability 255/255, txload Unknown, rxload Unknown
  Encapsulation ARPA, loopback not set,
  ARP type ARPA, ARP timeout 04:00:00
  Last clearing of "show interface" counters never
  5 minute input rate 0 bits/sec, 0 packets/sec
  5 minute output rate 0 bits/sec, 0 packets/sec
    375087 packets input, 22715308 bytes, 87 total input drops
    0 drops for unrecognized upper-level protocol
    Received 297320 broadcast packets, 0 multicast packets
      0 runts, 0 giants, 0 throttles, 0 parity
    48 input errors, 43 CRC, 0 frame, 0 overrun, 0 ignored, 0 abort
    89311 packets output, 6176363 bytes, 0 total output drops
    Output 53 broadcast packets, 0 multicast packets
    0 output errors, 0 underruns, 0 applique, 0 resets
    0 output buffer failures, 0 output buffers swapped out
    0 carrier transitions
```

Related Documents

Related Topic	Document Title
Additional information about configuring management interfaces	<i>Cisco ASR 9000 Series Aggregation Services Router Interface and Hardware Component Configuration Guide</i>

Manually Setting the Router Clock

Generally, if the system is synchronized by a valid outside timing mechanism, such as a Network Time Protocol (NTP) or VINES clock source, you need not set the software clock. Use the **clock set** command for initial configuration or if a network time source is not available.

The **clock timezone** command should be entered before the clock is set because it defines the difference between the system time and Coordinated Universal Time (UTC). When you set the time, you set the system time, and the router uses the **clock timezone** command setting to translate that time to UTC. The system internally keeps time in UTC. When you type the **show clock** command, the router displays the system time.

To manually set the router clock, complete the following steps:

SUMMARY STEPS

1. **configure**
2. **clock timezone** *zone hours-offset*
3. **commit**
4. **end**
5. **clock set** *hh:mm:ss dd mm yyyy*
6. **clock update-calendar**
7. **show clock**

DETAILED STEPS

	Command or Action	Purpose
Step 1	configure Example: RP/0/RSP0/CPU0:router# configure	Enters global configuration mode.
Step 2	clock timezone <i>zone hours-offset</i> Example: RP/0/RSP0/CPU0:router(config)# clock timezone pst -8	Sets the time zone for the router clock. <ul style="list-style-type: none"> • The clock timezone command should be entered before the clock is set because it defines the difference between the system time and UTC. <p>Note The system time is the time that appears when you type the show clock command.</p> <ul style="list-style-type: none"> • <i>zone</i>: Name of the time zone to be displayed when standard time is in effect. • <i>hours-offset</i>: Difference in hours from UTC.
Step 3	commit Example: RP/0/RSP0/CPU0:router(config-if)# commit	Commits the target configuration to the running configuration.
Step 4	end Example: RP/0/RSP0/CPU0:router(config-if)# end	Ends the configuration session and returns to EXEC mode.
Step 5	clock set <i>hh:mm:ss dd mm yyyy</i> Example: RP/0/RSP0/CPU0:router# clock set 14:12:00 10 dec 2008	Sets the system software clock.

Step 6	clock update-calendar	Updates the hardware clock (calendar clock) with the new clock settings.
	Example: RP/0/RSP0/CPU0:router# clock update-calendar	<ul style="list-style-type: none"> The hardware clock is battery operated and runs continuously, even if the router is powered off or rebooted.
Step 7	show clock	Displays the clock setting.
	Example: RP/0/RSP0/CPU0:router# show clock	<ul style="list-style-type: none"> Use this command to verify the settings.

Examples

In the following example, the manual system clock is configured:

```
RP/0/RSP0/CPU0:router# configure
RP/0/RSP0/CPU0:router(config)# clock timezone pst -8
RP/0/RSP0/CPU0:router(config)# commit
RP/0/RSP0/CPU0:router(config)# end
RP/0/RSP0/CPU0:router# clock set 14:12:00 10 dec 2008
14:12:00.090 PST Wed Dec 02 2008
RP/0/RSP0/CPU0:router# clock update-calendar
RP/0/RSP0/CPU0:router# show clock
14:12:00.090 PST Wed Dec 02 2008
```

Related Documents

Related Topic	Document Title
Descriptions of the clock commands	<i>Cisco ASR 9000 Series Aggregation Services Router System Management Command Reference</i>
Commands used to configure NTP	<i>Cisco ASR 9000 Series Aggregation Services Router System Management Command Reference</i>
Configuration of NTP	<i>Cisco ASR 9000 Series Aggregation Services Router System Management Configuration Guide</i>

Where to Go Next

When you have completed the configuration procedures in this chapter, consider the following resources for additional configuration documentation:

- For information on configuring additional general router features, see [Chapter 4, “Configuring Additional Router Features”](#).
- For information on using the Cisco IOS XR Software more efficiently, see [Chapter 5, “CLI Tips, Techniques, and Shortcuts.”](#)
- For information on configuring interfaces, see the hardware documents listed in [“Conventions”](#).



CHAPTER 4

Configuring Additional Router Features

This chapter shows you how to enter basic configurations using command-line interface (CLI).

Contents

- [Configuring the Domain Name and Domain Name Server, page 4-1](#)
- [Configuring Telnet and XML Host Services, page 4-3](#)
- [Managing Configuration History and Rollback, page 4-6](#)
- [Configuring Logging and Logging Correlation, page 4-12](#)
- [Creating and Modifying User Accounts and User Groups, page 4-15](#)
- [Configuring Software Entitlement, page 4-19](#)
- [Configuration Limiting, page 4-19](#)

Configuring the Domain Name and Domain Name Server

Configure a domain name and Domain Name Server (DNS) for your router to contact other devices on your network efficiently. Use the following guidelines:

- To define a default domain name that the Cisco IOS XR software uses to complete unqualified hostnames (names without a dotted-decimal domain name), use the **domain-name** command in global configuration mode.
- To specify the address of one or more name servers to use for name and address resolution, use the **domain name-server** command in global configuration mode. If no name server address is specified, the default name server is 255.255.255.255 so the DNS lookup can be broadcast to the local network segment. If a DNS server is in the local network, it replies. If not, there might be a server that knows how to forward the DNS request to the correct DNS server.
- Use the **show hosts** command in EXEC mode to display the default domain name, the style of name lookup service, a list of name server hosts, and the cached list of hostnames and addresses.

To configure the DNS and DNS server, complete the following steps:

SUMMARY STEPS

1. **configure**
2. **domain name** *domain-name-of-organization*
3. **domain name-server** *ipv4-address*
4. **commit**
or
end
5. **show hosts**

DETAILED STEPS

	Command or Action	Purpose
Step 1	configure Example: RP/0/RSP0/CPU0:router# configure	Enters global configuration mode.
Step 2	domain name <i>domain-name-of-organization</i> Example: RP/0/RSP0/CPU0:router(config)# domain name cisco.com	Defines a default domain name used to complete unqualified hostnames.
Step 3	domain name-server <i>ipv4-address</i> Example: RP/0/RSP0/CPU0:router(config)# domain name-server 192.168.1.111	Specifies the address of a name server to use for name and address resolution (hosts that supply name information). Note You can enter up to six addresses, but only one for each command.

	Command or Action	Purpose
Step 4	<pre>end or commit</pre> <p>Example:</p> <pre>RP/0/RSP0/CPU0:router(config)# end or RP/0/RSP0/CPU0:router(config)# commit</pre>	<p>Saves configuration changes.</p> <ul style="list-style-type: none"> When you issue the end command, the system prompts you to commit changes: <pre>Uncommitted changes found, commit them before exiting (yes/no/cancel)? [cancel]:</pre> <ul style="list-style-type: none"> Entering yes saves configuration changes to the running configuration file, exits the configuration session, and returns the router to EXEC mode. Entering no exits the configuration session and returns the router to EXEC mode without committing the configuration changes. Entering cancel leaves the router in the current configuration session without exiting or committing the configuration changes. Use the commit command to save the configuration changes to the running configuration file and remain within the configuration session.
Step 5	<pre>show hosts</pre> <p>Example:</p> <pre>RP/0/RSP0/CPU0:router(config)# show hosts</pre>	<p>Displays all configured name servers.</p>

Examples

In the following example, the domain name and DNS are configured:

```
RP/0/RSP0/CPU0:router# configure
RP/0/RSP0/CPU0:router(config)# domain name cisco.com
RP/0/RSP0/CPU0:router(config)# domain name-server 10.1.1.1
RP/0/RSP0/CPU0:router(config)# commit
RP/0/RSP0/CPU0:router(config)# end
RP/0/RSP0/CPU0:router# show hosts
```

```
Default domain is cisco.com
Name/address lookup uses domain service
Name servers: 10.1.1.1
```

Configuring Telnet and XML Host Services

For security, some host services are disabled by default. You can enable Host services, such as Telnet and Extensible Markup Language (XML), using the commands in this section. Enabling the Telnet server allows users to log in to the router using IPv4 Telnet clients.

Prerequisites

Ensure the following prerequisites are met before configuring Telnet and XML host services:

- For the XML host services, the Manageability package must be installed and activated on the router.
- To enable the Secure Socket Layer (SSL) of the XML services, the Security package must be installed and activated on the router.

See *Cisco ASR 9000 Series Aggregation Series Router System Management Configuration Guide* for information on installing and activating packages.

**Note**

This process enables the Telnet and XML host services on the Management Ethernet interfaces. For more information on how to enable these services on other inband interfaces, refer to the *Cisco ASR 9000 Series Aggregation Services Router System Security Configuration Guide*.

SUMMARY STEPS

1. **configure**
2. **telnet ipv4 server max-servers** *limit*
3. **end** or **commit**

DETAILED STEPS

	Command or Action	Purpose
Step 1	configure Example: RP/0/RSP0/CPU0:router# configure	Enters global configuration mode.
Step 2	telnet ipv4 server max-servers limit Example: RP/0/RSP0/CPU0:router(config)# telnet ipv4 server max-servers 5	Enables Telnet services on the router and specifies the maximum number of allowable Telnet servers.
Step 3	end or commit Example: RP/0/RSP0/CPU0:router(config)# end or RP/0/RSP0/CPU0:router(config)# commit	Saves configuration changes. <ul style="list-style-type: none"> When you issue the end command, the system prompts you to commit changes: Uncommitted changes found, commit them before exiting(yes/no/cancel)? [cancel]: <ul style="list-style-type: none"> Entering yes saves configuration changes to the running configuration file, exits the configuration session, and returns the router to EXEC mode. Entering no exits the configuration session and returns the router to EXEC mode without committing the configuration changes. Entering cancel leaves the router in the current configuration session without exiting or committing the configuration changes. Use the commit command to save the configuration changes to the running configuration file and remain within the configuration session.

Examples

In the following example, the host services are enabled:

```
RP/0/RSP0/CPU0:router# configure
RP/0/RSP0/CPU0:router(config)# telnet ipv4 server max-servers 5
RP/0/RSP0/CPU0:router(config)# http server
RP/0/RSP0/CPU0:router(config)# commit
```

Related Documents

Related Topic	Document Title
Installation and activation of the Manageability and Security Packages	<i>Cisco ASR 9000 Series Aggregation Services Router System Management Configuration Guide</i>
Descriptions of the XML server commands	<i>Cisco ASR 9000 Series Aggregation Services Router System Management Command Reference</i>

Managing Configuration History and Rollback

After each commit operation, the system saves a record of committed configuration changes. This record has only changes made during the configuration session; it does not contain the complete configuration. Each record is assigned a unique ID, a *commitID*. Using a commitID you can:

- Identify the previous configuration to which to return. Before rolling back the configuration to a specific commitID, consider the following:
 - You cannot roll back to a configuration removed because of package incompatibility. Configuration rollbacks only succeed when the configuration passes all compatibility checks with the active Cisco IOS XR Software release.
 - If the system finds an incompatible configuration during rollback, the operation fails and an error appears.
- Load configuration changes made during a configuration session
- Load configuration changes from multiple commitIDs
- Clear commitIDs

Cisco IOS XR automatically saves up to 100 of the most recent commitIDs.

The following sections describe how to manage configuration changes and roll back to a previously committed configuration:

- [Viewing CommitIDs, page 4-7](#)
- [Viewing Configuration Changes Recorded in a CommitID, page 4-7](#)
- [Previewing Rollback Configuration Changes, page 4-8](#)
- [Rolling Back the Configuration to a Specific Rollback Point, page 4-8](#)
- [Rolling Back the Configuration over a Specified Number of Commits, page 4-9](#)
- [Loading CommitID Configuration Changes to the Target Configuration, page 4-9](#)
- [Loading Rollback Configuration Changes to the Target Configuration, page 4-10](#)
- [Deleting CommitIDs, page 4-11](#)

Viewing CommitIDs

To view up to 100 of the most recent commitIDs, type the **show configuration commit list** command in EXEC or administration EXEC mode. Up to 100 of the most recent commitIDs are saved by the system. Each commitID entry shows the user who committed configuration changes, the connection used to execute the commit, and commitID time stamp.

The commitIDs are shown in the “Label/ID” column. The following example shows the **show configuration commit list** command display in EXEC and administration EXEC modes:

```
RP/0/RSP1/CPU0:router# show configuration commit list
```

SNo.	Label/ID	User	Line	Client	Time Stamp
1	1000000219	cisco	vty0	CLI	12:27:50 UTC Wed Mar 22 2008
2	1000000218	cisco	vty1	CLI	11:43:31 UTC Mon Mar 20 2008
3	1000000217	cisco	con0_RSP0_C	CLI	17:44:29 UTC Wed Mar 15 2008

```
RP/0/RSP1/CPU0:router# admin
RP/0/RSP1/CPU0:router(admin)# show configuration commit list
```

SNo.	Label/ID	User	Line	Client	Time Stamp
1	2000000022	cisco	vty1	CLI	15:03:59 UTC Fri Mar 17 2008
2	2000000021	cisco	con0_RSP0_C	CLI	17:42:55 UTC Wed Mar 15 2008
3	2000000020	SYSTEM	con0_RSP0_C	Setup Dial	17:07:39 UTC Wed Mar 15 2008

Viewing Configuration Changes Recorded in a CommitID

To view the configuration changes made during a specific commit session (commitID), go to EXEC or administration EXEC mode and type the **show configuration commit changes** command followed by a commitID number. The easiest way to determine the commitID is to type the **show configuration commit changes ?** command first. In the following example, the command help is used to display the available commitIDs, and then the changes for a specific commitID are displayed:

```
RP/0/RSP1/CPU0:router(admin)# show configuration commit changes ?
```

```

last          Changes made in the most recent <n> commits
since         Changes made since (and including) a specific commit
2000000020   Commit ID
2000000021   Commit ID
2000000022   Commit ID

```

```
RP/0/RSP1/CPU0:router(admin)# show configuration commit changes 2000000020
```

```

Building configuration...
username cisco
 secret 5 $1$MgUH$xzUEW6jLfYAYLKJE.3p440
 group root-system
!
end

```

Previewing Rollback Configuration Changes

The **show configuration rollback changes** command allows you to preview the configuration changes that take place if you roll back the configuration to a specific commitID. For example, if you want to roll back the configuration to a specific point, all configuration changes made after that point must be undone. This rollback process is often accomplished by executing the **no** version of commands that must be undone.

To display the prospective rollback configuration changes from the current configuration to a specific commitID, go to EXEC or administration EXEC mode and type the **show configuration rollback changes to commitId** command. In the following example, the command help displays the available commitIDs, and then the rollback changes are displayed.

```
RP/0/RSP1/CPU0:router# show configuration rollback changes to ?

    1000000217  Commit ID
    1000000218  Commit ID
    1000000219  Commit ID

RP/0/RSP1/CPU0:router# show configuration rollback changes to 1000000218

Building configuration...
no interface Loopback100
interface Gi0/1/0/0
  no ipv4 nd dad attempts
  !
  !
no route-policy xx
end
```

To display the prospective rollback configuration changes from the current configuration to a specified number of previous sessions, go to EXEC or administration EXEC mode and type the **show configuration rollback changes last commit-range** command:

```
RP/0/RSP0/CPU0:router# show configuration rollback changes last 2

Building configuration...
interface Loopback3
no description
no ipv4 address 10.0.1.1 255.0.0.0
exit
interface Loopback4
no description
no ipv4 address 10.0.0.1 255.0.0.0
end
```

In the preceding example, the command display shows the proposed rollback configuration changes for the last two commit IDs.

Rolling Back the Configuration to a Specific Rollback Point

When you roll back the configuration to a specific rollback point, you undo all configuration changes made during the session identified by the commit ID for that rollback point, and you undo all configuration changes made after that point. The rollback process rolls back the configuration and commits the rolled-back configuration. The rollback process also creates a new rollback point so that you can roll back the configuration to the previous configuration.

**Tip**

To preview the commands that undo the configuration during a rollback, use the **show configuration rollback changes** command.

To roll back the router configuration to a previously committed configuration, go to EXEC or administration EXEC mode and type the **rollback configuration to *commitId*** command:

```
RP/0/RSP1/CPU0:router# rollback configuration to 1000000220
Loading Rollback Changes.
Loaded Rollback Changes in 1 sec
Committing.
2 items committed in 1 sec (1)items/sec
Updating.
Updated Commit database in 1 sec
Configuration successfully rolled back to '1000000220'.
```

Rolling Back the Configuration over a Specified Number of Commits

When you roll back the configuration over a specific number of commits, you do not have to enter a specific commit ID. Instead, you specify a number x , and the software undoes all configuration changes made in the last x committed configuration sessions. The rollback process rolls back the configuration, commits the rolled-back configuration, and creates a new commitID for the previous configuration.

**Tip**

To preview the commands that undo the configuration during a rollback, use the **show configuration rollback changes** command.

To roll back to the last x commits made, go to EXEC or administration EXEC mode and type the **rollback configuration last x** command; x is a number ranging from 1 to the number of saved commits in the commit database.

In the following example, a request is made to roll back the configuration changes made during the previous two commits:

```
RP/0/RSP0/CPU0:router# rollback configuration last 2

Loading Rollback Changes.
Loaded Rollback Changes in 1 sec
Committing.
1 items committed in 1 sec (0)items/sec
Updating.
Updated Commit database in 1 sec
Configuration successfully rolled back 2 commits.
```

Loading CommitID Configuration Changes to the Target Configuration

If the changes saved for a specific commitID are close to what you want, but a rollback is not appropriate, you can load the configuration changes for a commitID into the target configuration, modify the target configuration, and then commit the new configuration. Unlike the rollback process, the loaded changes are not applied until you commit them.

**Note**

Unlike the rollback process, loading the commitID configuration changes loads only the changes made during that commit operation. The load process does not load all changes made between the commitID and the current committed configuration.

To load commitID changes in the target configuration, go to global configuration or administration configuration mode and type the **load commit changes** command with the commitID number. In the following example, show commands are used to display the changes for a commitID, the commitID configuration is loaded into the target configuration, and the target configuration appears:

```
RP/0/RSP1/CPU0:router# show configuration commit changes ?

last          Changes made in the most recent <n> commits
since         Changes made since (and including) a specific commit
1000000217    Commit ID
1000000218    Commit ID
1000000219    Commit ID
1000000220    Commit ID
1000000221    Commit ID

RP/0/RSP1/CPU0:router# show configuration commit changes 1000000219
Building configuration...
interface Loopback100
!
interface Gi0/1/0/0
  ipv4 nd dad attempts 50
!
end

RP/0/RSP1/CPU0:router# config

RP/0/RSP1/CPU0:router(config)# load commit changes 1000000219
Building configuration...
Loading.
77 bytes parsed in 1 sec (76)bytes/sec

RP/0/RSP1/CPU0:router(config)# show configuration

Building configuration...
interface Loopback100
!
interface Gi0/1/0/0
  ipv4 nd dad attempts 50
!
end
```

Loading Rollback Configuration Changes to the Target Configuration

If the changes for a specific rollback point are close to what you want, but a rollback is not appropriate, you can load the rollback configuration changes into the target configuration, modify the target configuration, and then commit the new configuration. Unlike the rollback process, the loaded changes are not applied until you commit them.

**Tip**

To display the rollback changes, type the **show configuration rollback changes** command.

To load rollback configuration changes from the current configuration to a specific session, go to global configuration or administration configuration mode and type the **load rollback changes to *commitId*** command:

```
RP/0/RSP0/CPU0:router(config)# load rollback changes to 1000000068

Building configuration...
Loading.
233 bytes parsed in 1 sec (231)bytes/sec
```

To load rollback configuration changes from the current configuration to a specified number of previous sessions, go to global configuration or administration configuration mode and type the **load rollback changes last *commit-range*** command:

```
RP/0/RSP0/CPU0:router(config)# load rollback changes last 6

Building configuration...
Loading.
221 bytes parsed in 1 sec (220)bytes/sec
```

In the preceding example, the command loads the rollback configuration changes for the last six commitIDs.

To load the rollback configuration for a specific commitID, go to global configuration or administration configuration mode and type the **load rollback changes *commitId*** command:

```
RP/0/RSP0/CPU0:router(config)# load rollback changes 1000000060

Building configuration...
Loading.
199 bytes parsed in 1 sec (198)bytes/sec
```

Deleting CommitIDs

You can delete the oldest configuration commitIDs by entering the **clear configuration commit** command in EXEC or administration EXEC mode. The **clear configuration commit** command must be followed by either the amount of disk space you want to reclaim or number of commitIDs you want to delete. To reclaim disk space from the oldest commitIDs, type the **clear configuration commit** command followed by the keyword **diskspace** and number of kilobytes to reclaim:

```
RP/0/RSP0/CPU0:router# clear configuration commit diskspace 50

Deleting 4 rollback points '1000000001' to '1000000004'
64 KB of disk space will be freed. Continue with deletion?[confirm]
```

To delete a specific number of the oldest commitIDs, type the **clear configuration commit** command followed by the keyword **oldest** and number of commitIDs to delete:

```
RP/0/RSP0/CPU0:router# clear configuration commit oldest 5

Deleting 5 rollback points '1000000005' to '1000000009'
80 KB of disk space will be freed. Continue with deletion?[confirm]
```

Configuring Logging and Logging Correlation

System messages generated by the Cisco IOS XR software can be logged to a variety of locations based on the severity level of the messages. For example, you could direct information messages to the system console and also log debugging messages to a network server.

In addition, you can define correlation rules that group and summarize related events, generate complex queries for the list of logged events, and retrieve logging events through an XML interface.

The following sections describe logging and the basic commands used to log messages in Cisco IOS XR software:

- [Logging Locations and Severity Levels, page 4-12](#)
- [Alarm Logging Correlation, page 4-13](#)
- [Configuring Basic Message Logging, page 4-13](#)
- [Disabling Console Logging, page 4-15](#)

Logging Locations and Severity Levels

Error messages can be logged to a variety of locations, as shown in [Table 4-1](#).

Table 4-1 Logging Locations for System Error Messages

Logging Destination	Command (Global Configuration Mode)
console	<code>logging console</code>
vt terminal	<code>logging monitor</code>
external syslog server	<code>logging trap</code>
internal buffer	<code>logging buffered</code>

You can log messages based on the severity level of the messages, as shown in [Table 4-2](#).

Table 4-2 Logging Severity Levels for System Error Messages

Level	Description
Level 0—Emergencies	System has become unusable.
Level 1—Alerts	Immediate action needed to restore system stability.
Level 2—Critical	Critical conditions that may require attention.
Level 3—Errors	Error conditions that may help track problems.
Level 4—Warnings	Warning conditions that are not severe.
Level 5—Notifications	Normal but significant conditions that bear notification.
Level 6—Informational	Informational messages that do not require action.
Level 7—Debugging	Debugging messages are for system troubleshooting only.

Alarm Logging Correlation

Alarm logging correlation is used to group and filter similar messages to reduce the amount of redundant logs and isolate the root causes of the messages.

For example, the original message describing the online insertion and removal (OIR) and system state being up or down can be reported, and all subsequent messages reiterating the same event can be correlated. When you create correlation rules, a common root event that is generating larger volumes of follow-on error messages can be isolated and sent to the correlation buffer. An operator can extract all correlated messages for display later, should the need arise. See *Cisco ASR 9000 Series Aggregation Services Router System Management Configuration Guide* for more information.

Configuring Basic Message Logging

Numerous options for logging system messages in Cisco IOS XR software are available. This section provides a basic example.

To configure basic message logging, complete the following steps:

SUMMARY STEPS

1. **configure**
2. **logging** {*ip-address* | *hostname*}
3. **logging trap** *severity*
4. **logging console** [*severity*]
5. **logging buffered** [*severity* | *buffer-size*]
6. **commit**
7. **end**
8. **show logging**

DETAILED STEPS

	Command or Action	Purpose
Step 1	configure Example: RP/0/RSP0/CPU0:router# configure	Enters global configuration mode.
Step 2	logging { <i>ip-address</i> <i>hostname</i> } Example: RP/0/RSP0/CPU0:router(config)# logging 10.1.1.1	Specifies a syslog server host to use for system logging.
Step 3	logging trap <i>severity</i> Example: RP/0/RSP0/CPU0:router(config)# logging trap debugging	Limits the logging of messages sent to syslog servers to only those messages at the specified level. <ul style="list-style-type: none"> • See Table 4-2 for a summary of the logging severity levels.

	Command or Action	Purpose
Step 4	logging console [<i>severity</i>] Example: RP/0/RSP0/CPU0:router(config)# logging console emergencies	Logs messages on the console. <ul style="list-style-type: none"> When a severity level is specified, only messages at that severity level are logged on the console. See Table 4-2 for a summary of the logging severity levels.
Step 5	logging buffered [<i>severity</i> <i>buffer-size</i>] Example: RP/0/RSP0/CPU0:router(config)# logging buffered 1000000	Copies logging messages to an internal buffer. <ul style="list-style-type: none"> Newer messages overwrite older messages after the buffer is filled. Specifying a severity level causes messages at that level and numerically lower levels to be logged in an internal buffer. See Table 4-2 for a summary of the logging severity levels. The buffer size is from 4096 to 4,294,967,295 bytes. Messages above the set limit are logged to the console.
Step 6	commit Example: RP/0/RSP0/CPU0:router(config)# commit	Commits the target configuration to the router running configuration.
Step 7	end Example: RP/0/RSP0/CPU0:router(config)# end	Ends the configuration session and returns to EXEC mode.
Step 8	show logging Example: RP/0/RSP0/CPU0:router# show logging	Displays the messages that are logged in the buffer.

Examples

In the following example, basic message logging is configured:

```
RP/0/RSP0/CPU0:router# configure
RP/0/RSP0/CPU0:router(config)# logging 10.1.1.1
RP/0/RSP0/CPU0:router(config)# logging trap debugging
RP/0/RSP0/CPU0:router(config)# logging console emergencies
RP/0/RSP0/CPU0:router(config)# logging buffered 1000000
RP/0/RSP0/CPU0:router(config)# commit
RP/0/RSP0/CPU0:router(config)# end
RP/0/RSP0/CPU0:router# show logging
```

```
Syslog logging: enabled (162 messages dropped, 0 flushes, 0 overruns)
  Console logging: level emergencies, 593 messages logged
  Monitor logging: level debugging, 0 messages logged
  Trap logging: level debugging, 2 messages logged
  Logging to 10.1.1.1, 2 message lines logged
  Buffer logging: level debugging, 722 messages logged
```

```
Log Buffer (1000000 bytes):
```

```

RP/0/RSP0/CPU0:Apr  8 19:18:58.679 : instdir[203]: %INSTALL-INSTMGR-6-INSTALL_OP
RP/0/RSP0/CPU0:Apr  8 19:19:01.287 : instdir[203]: %INSTALL-INSTMGR-6-INSTALL_OP
RP/0/RSP0/CPU0:Apr  8 19:22:15.658 : instdir[203]: %INSTALL-INSTMGR-6-INSTALL_OP
LC/0/1/CPU0:Apr  8 19:22:30.122 : sysmgr[74]: %OS-SYSMGR-7-INSTALL_NOTIFICATION
LC/0/6/CPU0:Apr  8 19:22:30.160 : sysmgr[74]: %OS-SYSMGR-7-INSTALL_NOTIFICATION
RP/0/RSP0/CPU0:Apr  8 19:22:30.745 : sysmgr[79]: %OS-SYSMGR-7-INSTALL_NOTIFICATION
RP/0/RSP1/CPU0:Apr  8 19:22:32.596 : sysmgr[79]: %OS-SYSMGR-7-INSTALL_NOTIFICATION
LC/0/1/CPU0:Apr  8 19:22:35.181 : sysmgr[74]: %OS-SYSMGR-7-INSTALL_FINISHED : s
LC/0/6/CPU0:Apr  8 19:22:35.223 : sysmgr[74]: %OS-SYSMGR-7-INSTALL_FINISHED : s
RP/0/RSP0/CPU0:Apr  8 19:22:36.122 : sysmgr[79]: %OS-SYSMGR-7-INSTALL_FINISHED :
RP/0/RSP1/CPU0:Apr  8 19:22:37.790 : sysmgr[79]: %OS-SYSMGR-7-INSTALL_FINISHED :
RP/0/RSP0/CPU0:Apr  8 19:22:41.015 : schema_server[332]: %MGBL-SCHEMA-6-VERSIONC
RP/0/RSP0/CPU0:Apr  8 19:22:59.844 : instdir[203]: %INSTALL-INSTMGR-4-ACTIVE_SOF
RP/0/RSP0/CPU0:Apr  8 19:22:59.851 : instdir[203]: %INSTALL-INSTMGR-6-INSTALL_OP
--More--

```

Related Documents

Related Topic	Document Title
Configuration of system logging	<i>Cisco ASR 9000 Series Aggregation Services Router System Monitoring Configuration Guide</i>
Commands used to configure logging	<i>Cisco ASR 9000 Series Aggregation Services Router System Monitoring Command Reference</i>
Configuration of alarm correlation and generating complex queries	<i>Cisco ASR 9000 Series Aggregation Services Router System Management Configuration Guide</i>
Commands used to configure alarm correlation	<i>Cisco ASR 9000 Series Aggregation Services Router System Management Command Reference</i>
Retrieve logging events through an XML interface	<i>Cisco ASR 9000 Series Aggregation Services Router XML API Guide</i>

Disabling Console Logging

To disable console logging, type the **logging console disable** command in global configuration mode.

Creating and Modifying User Accounts and User Groups

In the Cisco IOS XR software, users are assigned individual usernames and passwords. Each username is assigned to one or more user groups, each of which defines display and configuration commands the user is authorized to execute. This authorization is enabled by default in the Cisco IOS XR software, and each user must log in to the system using a unique username and password.

The following sections describe the basic commands used to configure users and user groups:

- [Viewing Details About User Accounts, User Groups, and Task IDs](#), page 4-16
- [Configuring User Accounts](#), page 4-17
- [Creating Users and Assigning Groups](#), page 4-17

For a summary of user accounts, user groups, and task IDs, see the “[User Groups, Task Groups, and Task IDs](#)” section on page 3-7

**Note**

The management of user accounts, user groups, and task IDs is part of the authentication, authorization, and accounting (AAA) feature. AAA is a suite of security features in the Cisco IOS XR software. For more information on the AAA, see the *Cisco ASR 9000 Series Aggregation Services Router System Security Configuration Guide* and *Cisco ASR 9000 Series Aggregation Services Router System Security Command Reference*. For instructions to activate software packages, see *Cisco ASR 9000 Series Aggregation Services Router System Management Configuration Guide*.

Viewing Details About User Accounts, User Groups, and Task IDs

Table 4-3 summarizes the EXEC mode commands used to display details about user accounts, user groups, and task IDs.

Table 4-3 Commands to Display Details About Users and User Groups

Command	Description
<code>show aaa userdb <i>username</i></code>	Displays the task IDs and privileges assigned to a specific username. To display all users on the system, type the command without a username.
<code>show aaa usergroup <i>usergroup-name</i></code>	Displays the task IDs and privileges that belong to a user group. To display all groups on the system, type the command without a group name.

Configuring User Accounts

User accounts, user groups, and task groups are created by entering the appropriate commands in one of the AAA configuration submodes, as shown in [Figure 4-1](#).

This section describes the process to configure usernames. For instructions to configure user groups, task groups, and other AAA security features, see the *Cisco ASR 9000 Series Aggregation Services Router System Security Configuration Guide*.

Figure 4-1 AAA Configuration Submodes

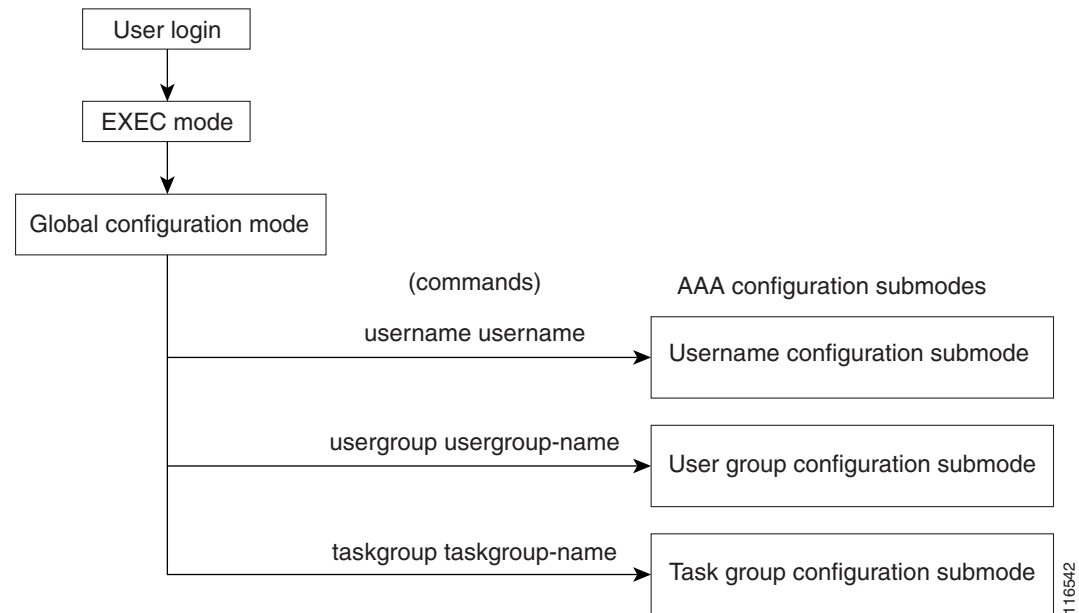

Creating Users and Assigning Groups

To create a user, assign a password, and assign the user to a group, perform the following procedure.

SUMMARY STEPS

1. **configure**
2. **username** *user-name*
3. **password** {0 | 7} *password*
or
secret {0 | 5} *password*
4. **group** *group-name*
5. Repeat Step 4 for each user group to be associated with the user specified in Step 2.
6. **commit**

DETAILED STEPS

	Command or Action	Purpose
Step 1	configure Example: RP/0/RSP0/CPU0:router# configure	Enters global configuration mode.
Step 2	username <i>user-name</i> Example: RP/0/RSP0/CPU0:router(config)# username user1	Creates a name for a new user (or identifies a current user) and enters username configuration submenu. <ul style="list-style-type: none"> The <i>user-name</i> argument can be only one word. Spaces and quotation marks are not allowed.
Step 3	password {0 7} <i>password</i> OR secret {0 5} <i>password</i> Example: RP/0/RSP0/CPU0:router(config-un)# password 0 pwd1 OR RP/0/RSP0/CPU0:router(config-un)# secret 5 pwd1	Specifies a password for the user named in Step 2. <ul style="list-style-type: none"> Use the secret command to create a secure login password for the user names specified in Step 2. Entering 0 following the password command specifies that an unencrypted (clear-text) password follows. Entering 7 following the password command specifies that an encrypted password follows. Entering 0 following the secret command specifies that a secure unencrypted (clear-text) password follows. Entering 5 following the secret command specifies that a secure encrypted password follows. Type 0 is the default for the password and secret commands.
Step 4	group <i>group-name</i> Example: RP/0/RSP0/CPU0:router(config-un)# group sysadmin	Assigns the user named in Step 2 to a user group. <ul style="list-style-type: none"> The user takes on all attributes of the user group, as defined by the user group association to various task groups. Each user must be assigned to at least one user group. A user may belong to multiple user groups.
Step 5	Repeat Step 4 for each user group to be associated with the user specified in Step 2.	—
Step 6	commit Example: RP/0/RSP0/CPU0:router(config-un)# commit	Saves configuration changes and activates them as part of the running configuration.

Related Documents

Related Topic	Document Title
Create users, assign users to user groups, create and modify user groups, and configure remote AAA access	<i>Cisco ASR 9000 Series Aggregation Services Router System Security Configuration Guide</i>

Configuring Software Entitlement

Certain software and hardware features are enabled using software entitlement, which is a system that consists of a license manager on a Cisco IOS XR device that manages licenses for various software and hardware features. The license manager parses and authenticates a license before accepting it. The software features on the router use the license manager APIs to check out and release licenses. Licenses are stored in persistent storage on the router.

All core routing features are available for use without any license. In Cisco IOS XR Software Release 3.7, the following features must be enabled with licenses:

- Layer 3 VPN
- Modular services card bandwidth

Refer to the *Cisco ASR 9000 Series Aggregation Services Router System Management Configuration Guide* for more information on configuring software licenses.

Configuration Limiting

The Cisco IOS XR software places preset limits on the configurations you can apply to the running configuration of a router. These limits ensure that the router has sufficient system resources (such as RAM) for normal operations. Under most conditions, these preset limits are sufficient.

In some cases, for which a large number of configurations is required for a particular feature, it may be necessary to override the preset configuration limits. This override can be done only if configurations for another feature are low or unused.

**Caution**

Overriding the default configuration limits can result in a low-memory condition.

The following sections describe the limits you can configure, default and maximum values, and commands for configuring and displaying the configuration limits:

- [Static Route Configuration Limits, page 4-20](#)
- [IS-IS Configuration Limits, page 4-20](#)
- [OSPFv2 and v3 Configuration Limits, page 4-21](#)
- [Routing Policy Language Line and Policy Limits, page 4-23](#)
- [Multicast Configuration Limits, page 4-25](#)
- [MPLS Configuration Limits, page 4-26](#)
- [Other Configuration Limits, page 4-26](#)

Static Route Configuration Limits

Table 4-4 summarizes the maximum limits for static routes, including the commands used to display and change the limits.

Table 4-4 Static Route Configuration Limits and Commands

Feature Limit Description	Default Maximum Limit	Absolute Maximum Limit	Configuration Command (Static Router Configuration Mode)	Show Current Settings Command (EXEC or Global Configuration Mode)
Maximum static IPv4 routes	4000	40,000	<code>maximum path ipv4 n</code>	<code>show running-config router static</code>

Examples

In the following example, the maximum number of static IPv4 routes is changed to 5000 and the new configuration appears.

```
RP/0/RSP1/CPU0:router# configure
RP/0/RSP1/CPU0:router(config)# router static
RP/0/RSP1/CPU0:router(config-static)# maximum path ipv4 5000
RP/0/RSP1/CPU0:router(config-static)# commit
RP/0/RSP1/CPU0:router(config-static)# show running-config router static

router static
 maximum path ipv4 5000
 address-family ipv4 unicast
  0.0.0.0/0 172.29.52.1
 !
 !
```

IS-IS Configuration Limits

Table 4-5 summarizes the maximum limits for Intermediate System to Intermediate System (IS-IS) routing protocol, including the commands used to display and change the limits.

Table 4-5 IS-IS Configuration Limits and Commands

Feature Limit Description	Default Maximum Limit	Absolute Maximum Limit	Configuration Command (Address Family Configuration Mode)	Show Current Settings Command (EXEC Mode)
Maximum number of prefixes redistributed into IS-IS	10,000	28,000	<code>maximum-redistributed-prefixes n</code>	<code>show isis adjacency</code>
Number of active parallel paths for each route on a Cisco ASR 9000 Series Router	8	32	<code>maximum-paths n</code>	<code>show isis route</code>

Examples

In the following example, the maximum number of active parallel paths for each route is increased to 10, and the maximum number of prefixes redistributed into IS-IS is increased to 12,000:

```
RP/0/RSP1/CPU0:router# configure
RP/0/RSP1/CPU0:router(config)# router isis 100 address-family ipv4
RP/0/RSP1/CPU0:router(config-isis-af)# maximum-paths 10
RP/0/RSP1/CPU0:router(config-isis-af)# maximum-redistributed-prefixes 12000
RP/0/RSP1/CPU0:router(config-isis-af)# commit
RP/0/RSP1/CPU0:Mar 30 14:11:07 : config[65739]: %LIBTARCFG-6-COMMIT : Configuration
committed by user 'cisco'. Use 'show configuration commit changes 1000000535' to view
the changes.
RP/0/RSP1/CPU0:router(config-isis-af)#
```

OSPFv2 and v3 Configuration Limits

Table 4-6 summarizes the maximum limits for Open Shortest Path First (OSPF) protocol, including the commands used to display and change the limits.

Table 4-6 OSPFv2 Configuration Limits and Commands

Feature Limit Description	Default Maximum Limit	Absolute Maximum Limit	Configuration Command (Router Configuration Mode)	Show Current Settings Command (EXEC Mode)
Maximum number of interfaces that can be configured for an OSPF instance	255	1024	maximum interfaces <i>n</i>	show ospf
Maximum routes redistributed into OSPF	10,000	4294967295	maximum redistributed-prefixes <i>n</i>	show ospf Note The maximum number of redistributed prefixes appear only if redistribution is configured.
Maximum number of parallel routes (maximum paths) on Cisco ASR 9000 Series routers	32	32	maximum paths <i>n</i>	show running-config router ospf Note This command shows only changes to the default value. If the maximum paths command does not appear, the router is set to the default value.

Examples

The following examples illustrate OSPF configuration limits:

- [Maximum Interfaces for Each OSPF Instance: Example, page 4-22](#)
- [Maximum Routes Redistributed into OSPF: Example, page 4-22](#)
- [Number of Parallel Links \(max-paths\): Example, page 4-23](#)

Maximum Interfaces for Each OSPF Instance: Example

In the following example, the **show ospf** command is used to display the maximum number of OSPF interfaces:

```
RP/0/RSP1/CPU0:router# show ospf

Routing Process "ospf 100" with ID 0.0.0.0
Supports only single TOS(TOS0) routes
Supports opaque LSA
It is an area border router
Initial SPF schedule delay 5000 msec
Minimum hold time between two consecutive SPF's 10000 msec
Maximum wait time between two consecutive SPF's 10000 msec
Initial LSA throttle delay 500 msec
Minimum hold time for LSA throttle 5000 msec
Maximum wait time for LSA throttle 5000 msec
Minimum LSA interval 5 secs. Minimum LSA arrival 1 sec
Maximum number of configured interfaces 255
--More--
```

The following example configures the maximum interface limit on a router:

```
RP/0/RSP1/CPU0:router# configure
RP/0/RSP1/CPU0:router(config)# router ospf 100
RP/0/RSP1/CPU0:router(config-router)# maximum interfaces 600
RP/0/RSP1/CPU0:router(config-router)# end
Uncommitted changes found, commit them? [yes]: y

RP/0/RSP1/CPU0:Mar 30 16:12:39 : config[65740]: %LIBTARCFG-6-COMMIT : Configuration
committed by user 'cisco'. Use 'show configuration commit changes 1000000540' to view
the changes.
RP/0/RSP1/CPU0:Mar 30 16:12:39 : config[65740]: %SYS-5-CONFIG_I : Configured from console
by cisco

RP/0/RSP1/CPU0:router# show ospf

Routing Process "ospf 100" with ID 0.0.0.0
Supports only single TOS(TOS0) routes
Supports opaque LSA
It is an area border router
Initial SPF schedule delay 5000 msec
Minimum hold time between two consecutive SPF's 10000 msec
Maximum wait time between two consecutive SPF's 10000 msec
Initial LSA throttle delay 500 msec
Minimum hold time for LSA throttle 5000 msec
Maximum wait time for LSA throttle 5000 msec
Minimum LSA interval 5 secs. Minimum LSA arrival 1 sec
Maximum number of configured interfaces 600
--More--
```

Maximum Routes Redistributed into OSPF: Example

In the following example, the **maximum redistributed-prefixes** command is used to set the maximum routes redistributed into OSPF:

```
RP/0/RSP1/CPU0:router# configure
RP/0/RSP1/CPU0:router(config)# router ospf 100
RP/0/RSP1/CPU0:router(config-router)# maximum redistributed-prefixes 12000
RP/0/RSP1/CPU0:router(config-router)# end
Uncommitted changes found, commit them? [yes]: y
```

```
RP/0/RSP1/CPU0:Mar 30 16:26:52 : config[65740]: %LIBTARCFG-6-COMMIT : Configuration
committed by user 'cisco'. Use 'show configuration commit changes 1000000541' to view
the changes.
RP/0/RSP1/CPU0:Mar 30 16:26:52 : config[65740]: %SYS-5-CONFIG_I : Configured from console
by cisco
RP/0/RSP1/CPU0:router#
```

Number of Parallel Links (max-paths): Example

In the following example, the **maximum paths** command is used to set the maximum number of parallel routes:

```
RP/0/RSP1/CPU0:router# configure
RP/0/RSP1/CPU0:router(config)# router ospf 100
RP/0/RSP1/CPU0:router(config-router)# maximum paths 10
RP/0/RSP1/CPU0:router(config-router)# end
Uncommitted changes found, commit them? [yes]: y

RP/0/RSP1/CPU0:Mar 30 18:05:13 : config[65740]: %LIBTARCFG-6-COMMIT : Configuration
committed by user 'cisco'. Use 'show configuration commit changes 1000000542' to view
the changes.
RP/0/RSP1/CPU0:Mar 30 18:05:13 : config[65740]: %SYS-5-CONFIG_I : Configured from console
by cisco
RP/0/RSP1/CPU0:router#
```

Routing Policy Language Line and Policy Limits

Two limits for Routing Policy Language (RPL) configurations exist:

1. Number of RPL lines: The number of configuration lines entered by the user, including the beginning and ending statements (that is “route-policy”). The number of configuration lines for sets is also included.
2. Number of RPL policies: The number of policies that can be configured on the router. Policies are counted only once: Multiple use of the same policy counts as a single policy toward the limit 1.

The limits for RPL lines and policies are summarized in [Table 4-7](#). You can change the default values up to the absolute maximum, but you cannot change the value to a number less than the number of items that are currently configured.

Table 4-7 Maximum Lines of RPL: Configuration Limits and Commands

Limit Description	Default Maximum Limit	Absolute Maximum Limit	Configuration Command (Global Configuration Mode)	Show Current Settings Command (EXEC Mode)
Maximum number of RPL lines	65,536	131,072	rpl maximum lines <i>n</i>	show rpl maximum lines
Maximum number of RPL policies	3500	5000	rpl maximum policies <i>n</i>	show rpl maximum policies

Examples

In the following example, the **show rpl maximum** command is used in EXEC mode to display the current setting for RPL limits and number of each limit currently in use. A summary of the memory used by all of the defined policies is also shown below the limit settings.

```
RP/0/RSP1/CPU0:router# show rpl maximum
```

	Current Total	Current Limit	Max Limit
Lines of configuration	0	65536	131072
Policies	0	3500	5000
Compiled policies size (kB)	0		

```
RP/0/RSP1/CPU0:router#
```

In the next example, the **rpl maximum** command changes the currently configured line and policy limits. The **show rpl maximum** command displays the new settings.

```
RP/0/RSP1/CPU0:router# configure
RP/0/RSP1/CPU0:router(config)# rpl maximum policies 4000
RP/0/RSP1/CPU0:router(config)# rpl maximum lines 80000
RP/0/RSP1/CPU0:router(config)# commit

RP/0/RSP1/CPU0:Apr 1 00:23:44.062 : config[65709]: %LIBTARCFG-6-COMMIT : Configuration
committed by user 'UNKNOWN'. Use 'show configuration commit changes 1000000010' to view
the changes.
RP/0/RSP1/CPU0:router(config)# exit

RP/0/RSP1/CPU0:Apr 1 00:23:47.781 : config[65709]: %SYS-5-CONFIG_I : Configured from
console by console

RP/0/RSP1/CPU0:router# show rpl maximum
```

	Current Total	Current Limit	Max Limit
Lines of configuration	0	80000	131072
Policies	0	4000	5000
Compiled policies size (kB)	0		

```
RP/0/RSP1/CPU0:router#
```

Multicast Configuration Limits

Table 4-8 summarizes the maximum limits for multicast configuration, including the commands used to display and change the limits.

Table 4-8 Multicast Configuration Limits and Commands

Feature Limit Description	Default Maximum Limit	Absolute Maximum Limit	Configuration Command	Show Current Settings Command (EXEC Mode)
Internet Group Management Protocol (IGMP) Limits				
Maximum number of groups used by IGMP and accepted by a router	50,000	75,000	maximum groups <i>n</i> (router IGMP configuration mode)	show igmp summary
Maximum number of groups for each interface accepted by a router	25,000	40,000	maximum groups-per-interface <i>n</i> (router IGMP interface configuration mode)	show igmp summary
Multicast Source Discovery Protocol (MSDP) Limits				
Maximum MSDP Source Active (SA) entries	20,000	75,000	maximum external-sa <i>n</i> (router MSDP configuration mode)	show msdp summary
Maximum MSDP SA entries that can be learned from MSDP peers	20,000	75,000	maximum peer-external-sa <i>n</i> (router MSDP configuration mode)	show msdp summary
Protocol Independent Multicast (PIM) Limits				
Maximum PIM routes supported	100,000	200,000	maximum routes <i>n</i> (router PIM configuration mode)	show pim summary
Maximum PIM egress states	300,000	600,000	maximum route-interfaces <i>n</i> (router PIM configuration mode)	show pim summary
Maximum PIM registers	20,000	75,000	maximum register-states <i>n</i> (router PIM configuration mode)	show pim summary
Maximum number of PIM group map ranges learned from Auto-RP	500	5000	maximum group-mappings autorp <i>n</i> (router PIM configuration mode)	show pim summary

MPLS Configuration Limits

Table 4-9 summarizes the maximum limits for Multiprotocol Label Switching (MPLS) configuration, including the commands used to display and change the limits.

Table 4-9 *MPLS Configuration Limits and Commands*

Limit Description	Default	Absolute Maximum Limit	Configuration Command (Global Configuration Mode)	Show Current Settings Command (EXEC Mode)
Maximum traffic engineer (TE) tunnels head	2500	65536	<code>mpls traffic-eng maximum tunnels n</code>	<code>show mpls traffic-eng maximum tunnels</code>

Other Configuration Limits

Table 4-10 summarizes the maximum limits for additional configuration limits, including the commands used to display and change the limits.

Table 4-10 *Additional Configuration Limits and Commands*

Limit Description	Default Maximum Limit	Absolute Maximum Limit	Configuration Command (Global Configuration Mode)	Show Current Settings Command (EXEC Mode)
IPv4 ACL (access list and prefix list)	5000	16000	<code>ipv4 access-list maximum acl threshold n</code>	<code>show access-lists ipv4 maximum</code>
IPv4 ACE (access list and prefix list)	200,000	350,000	<code>ipv4 access-list maximum ace threshold n</code>	<code>show access-lists ipv4 maximum</code>



CHAPTER 5

CLI Tips, Techniques, and Shortcuts

This chapter describes techniques for using the command-line interface (CLI) of the Cisco IOS XR software.

Contents

- [CLI Tips and Shortcuts, page 5-1](#)
- [Viewing System Information with show Commands, page 5-5](#)
- [Wildcards, Templates, and Aliases, page 5-12](#)
- [Command History, page 5-17](#)
- [Key Combinations, page 5-18](#)



Note

Commands can be entered in uppercase, lowercase, or mixed case. Only passwords are case sensitive. However, the Cisco Systems documentation convention presents commands in lowercase.

CLI Tips and Shortcuts

The following sections describe tips and shortcuts useful when using the CLI:

- [Entering Abbreviated Commands, page 5-1](#)
- [Using the Question Mark \(?\) to Display On-Screen Command Help, page 5-2](#)
- [Completing a Partial Command with the Tab Key, page 5-4](#)
- [Identifying Command Syntax Errors, page 5-4](#)
- [Using the no Form of a Command, page 5-4](#)
- [Editing Command Lines that Wrap, page 5-5](#)

Entering Abbreviated Commands

You can abbreviate commands and keywords to the number of characters that allow a unique abbreviation. For example, the **configure** command can be abbreviated as **config** because the abbreviated form of the command is unique. The router accepts and executes the abbreviated command.

Using the Question Mark (?) to Display On-Screen Command Help

Use the question mark (?) to learn what commands are available and the correct syntax for a command. [Table 5-1](#) summarizes the options for on-screen help.



Tip

The space (or no space) before the question mark (?) is significant. If you include a space before the question mark, the system displays all available options for a command or CLI mode. If you do not include a space, the system displays a list of commands that begin with a particular character string.

Table 5-1 On-Screen Help Commands

Command	Description
<i>partial-command?</i>	Type a question mark (?) at the end of a partial command to list the commands that begin with those characters. RP/0/RSP0/CPU0:router# co? configure copy Note Do not include a space between the command and question mark.
?	Lists all commands available for a particular command mode.
<i>command ?</i>	Include a space before the question mark (?) to list the keywords and arguments that belong to a command. RP/0/RSP0/CPU0:router# configure ? exclusive Configure exclusively from this terminal terminal Configure from the terminal <cr> Note For most commands, the <cr> symbol indicates that you can execute the command with the syntax already entered. For the preceding example, press Enter to enter global configuration mode.
<i>command keyword ?</i>	Type a question mark (?) after the keyword to list the next available syntax option for the command. RP/0/RSP0/CPU0:router# show aaa ? taskgroup Show all the local taskgroups configured in the system userdb Show all local users with the usergroups each belong to usergroup Show all the local usergroups configured in the system Note Include a space between the keyword and question mark.

The following example shows how to add an entry to access list 99. The added entry denies access to all hosts on subnet 172.0.0.0 and ignores bits for IPv4 addresses that start within the range of 0 to 255. The following steps provide an example of on-screen command help:

Step 1 Type the **access-list** command, followed by a space and a question mark, to list the available options for the command:

```
RP/0/RSP0/CPU0:router(config)# ipv4 access-list ?

log-update   Control access lists log updates
maximum      Out of resources configuration
WORD         Access list name - maximum 32 characters
```

**Note**

The number ranges (within the angle brackets) are inclusive ranges.

- Step 2** Type the access list name **list1**, followed by a space and another question mark, to display the arguments that apply to the keyword and brief explanations:

```
RP/0/RSP0/CPU0:router(config)# ipv4 access-list list1 ?

<1-2147483646>  Sequence number for this entry
deny           Specifies packets to reject
permit        Specifies packets to forward
remark        Comment for access list
<cr>
RP/0/RSP0/CPU0:router(config)#ipv4 access-list list1
```

- Step 3** Type the **deny** option and a question mark to see more command options:

```
RP/0/RSP0/CPU0:router(config)# ipv4 access-list list1 deny ?

<0-255>  An IPv4 Protocol Number
A.B.C.D  Source IP address or prefix
ahp      Authentication Header Protocol
any      Any source host
eigrp    Cisco's EIGRP Routing Protocol
esp      Encapsulation Security Payload
gre      Cisco's GRE Tunneling
host     A single source host
icmp     Internet Control Message Protocol
igmp     Internet Gateway Message Protocol
igrp     Cisco's IGRP Routing Protocol
ipinip   IP in IP tunneling
ipv4     Any IPv4 Protocol
nos      KA9Q NOS Compatible IP over IP Tunneling
ospf     OSPF Routing Protocol
pcp      Payload Compression Protocol
pim      Protocol Independent Multicast
sctp     Stream Control Transmission Protocol
tcp      Transport Control Protocol
udp      User Datagram Protocol
RP/0/RSP0/CPU0:router(config)#ipv4 access-list list1 deny
```

- Step 4** Type an IP address, followed by a space and a question mark (?), to list additional options:

```
RP/0/RSP0/CPU0:router(config)# ipv4 access-list list1 deny 172.31.134.0 ?

A.B.C.D  Wildcard bits
log       Log matches against this entry
log-input Log matches against this entry, including input interface
<cr>
RP/0/RSP0/CPU0:router(config)# ipv4 access-list list1 deny 172.31.134.0
```

The <cr> symbol by itself indicates that there are no more keywords or arguments.

- Step 5** Press **Enter** to execute the command:

```
RP/0/RSP0/CPU0:router(config)# ipv4 access-list list1 deny 172.31.134.0
```

**Note**

The configuration does not become active until you type the **commit** command to add the target configuration to the running configuration.

Completing a Partial Command with the Tab Key

If you cannot remember a complete command name or want to reduce the amount of typing you have to perform, type the first few letters of the command, then press the Tab key. If only one command begins with that character string, the system completes the command for you. If the characters you entered indicate more than one command, the system beeps to indicate that the text string is not unique and the system provides a list of commands that match the text entered.

In the following example, the CLI recognizes **conf** as a unique string in EXEC mode and completes the command when you press the Tab key:

```
RP/0/RSP0/CPU0:router# conf <Tab>
RP/0/RSP0/CPU0:router# configure
```

The CLI displays the full command name, but you must press **Enter** to execute the command. This allows you to modify or reject the suggested command.

In the next example, the CLI recognizes two commands that match the text entered:

```
RP/0/RSP1/CPU0:router# co<Tab>
configure copy
RP/0/RSP1/CPU0:router# con<Tab>
RP/0/RSP1/CPU0:router# configure
```



Tip

If your keyboard does not have a Tab key, press Ctrl-I instead.

Identifying Command Syntax Errors

If an incorrect command is entered, an error message is returned with the caret (^) at the point of the error. In the following example, the caret appears where the character was typed incorrectly in the command:

```
RP/0/RSP0/CPU0:router# configure termiMal
                                     ^
% Invalid input detected at '^' marker.
```



Note

The percent sign (%) indicates the line in which the error message occurred.

To display the correct command syntax, type the “?” after the command:

```
RP/0/RSP0/CPU0:router# configure ?

exclusive  Configure exclusively from this terminal
terminal   Configure from the terminal
<cr>
```

Using the no Form of a Command

Almost every configuration command has a **no** form. Depending on the command, the **no** form may enable or disable a feature. For example, when configuring an interface, the **no shutdown** command brings up the interface, and the **shutdown** command shuts down the interface. The **username** command creates a new user, and the **no username** command deletes a user when entered with a valid username.

The Cisco IOS XR software command reference publications provide the complete syntax for the configuration commands and describe what the **no** form of a command does. See the “[Conventions](#)” section on page xii for more information.

Editing Command Lines that Wrap

The CLI provides a wraparound feature for commands that extend beyond a single line on the screen. When the cursor reaches the right margin, the command line shifts ten spaces to the left. The first ten characters of the line are not shown, but it is possible to scroll back and check the syntax at the beginning of the command. To scroll back, press Ctrl-B or the left arrow key repeatedly, or press Ctrl-A to return directly to the beginning of the line.

In the following example, the **ipv4 access-list** command entry is too long to display on one line. When the cursor reaches the end of the line, the line is shifted to the left and redisplayed. The dollar sign (\$) after the command prompt indicates that the line has been scrolled to the left and the beginning of the command is hidden.

```
RP/0/RSP0/CPU0:router(config)# $s-list 101 permit tcp 172.31.134.5 255.255.255.0
172.31.135.0
```

In the next example, Ctrl-A is used to display the beginning of the command line, and the dollar sign at the end of the command line shows the command has been scrolled to the right and the end of the command is hidden.

```
RP/0/RSP0/CPU0:router(config)# ipv4 access-list 101 permit tcp 172.31.134.5 255.255.255.0
17$
```

In the next example, the right arrow key has been used to scroll to the right. Notice that dollar sign symbols appear at both ends of the line, which indicates that command information is hidden from the beginning and end of the command.

```
RP/0/RSP0/CPU0:router(config)# $ccess-list 101 permit tcp 172.31.134.5 255.255.255.0
172.31.$
```

By default, the Cisco IOS XR software uses a terminal screen 80 columns wide. To adjust for a different screen width, use the **terminal width** command in EXEC mode.

Use line wrapping with the command history feature to recall and modify previous complex command entries.

Viewing System Information with show Commands

The **show** commands display information about the system and its configuration. The following sections describe some common **show** commands and provide techniques to manage the output from those commands:

- [Common show Commands, page 5-6](#)
- [Browsing Display Output when the --More-- Prompt Appears, page 5-6](#)
- [Halting the Display of Screen Output, page 5-7](#)
- [Redirecting Output to a File, page 5-7](#)
- [Narrowing Output from Large Configurations, page 5-8](#)
- [Filtering show Command Output, page 5-9](#)

Common show Commands

Some of the most common **show** commands are described in [Table 5-2](#).

Table 5-2 Common show Commands in Cisco IOS XR Software

Command	Description	Command Mode
show version	Displays system information.	EXEC or administration EXEC mode
show configuration	Displays the uncommitted configuration changes made during a configuration session.	Global or administration configuration mode
show running-config (EXEC or global configuration mode)	Displays the current running configuration for the RP to which you are connected.	EXEC or global configuration mode
show running-config (administration EXEC or administration configuration mode)	Displays the current running configuration that applies to the entire router.	administration EXEC or administration configuration mode
show tech-support	Collects a large amount of system information for troubleshooting. You can provide this output to technical support representatives when reporting a problem.	EXEC or administration EXEC mode
show platform (EXEC mode)	Displays information about cards and modules assigned to the RP to which you are connected.	EXEC mode
show platform (administration EXEC mode)	Displays information about all cards and modules in the router.	administration EXEC mode
show environment	Displays hardware information for the system, including fans, LEDs, power supply voltage and current, and temperatures. Type show environment ? to see additional command options.	EXEC mode or administration EXEC mode

For more information on the use of these commands, see the “[Conventions](#)” section on page xii.

Browsing Display Output when the --More-- Prompt Appears

When command output requires more than one screen, such as for the **?**, **show**, or **more** command, the output is presented one screen at a time, and a **--More--** prompt appear at the bottom of the screen.

To display additional command output, do one of the following:

- Press **Enter** to display the next line.
- Press the space bar to display the next screen of output.

The following example shows one screen of data and the `--More--` prompt:

```
RP/0/RSP0/CPU0:router# show ?

aaa                Show AAA configuration and operational data
adjacency          Adjacency information
aliases            Display alias commands
alphadisplay       Shows the message being displayed on the alpha display
aps                SONET APS information
arm                IP ARM information
arp                ARP table
as-path-access-list List AS path access lists
asic-errors        ASIC error information
atc                Attractor Cache related
auto-rp            Auto-RP Commands
buffer-manager     Show all buffer manager memory related information
bundle             Show hardware related information for Bundles.
calendar           Display the system calendar
cdp                CDP information
cef                Cisco Express Forwarding
cetftp             HFR control plane ethernet TFTP server
checkpoint         Show checkpoint services
cinetd             cinetd daemon
clns                Display CLNS related information
clock              Display the system clock
commit             Show commit information
--More--
```



Tip

If you do not see the `--More--` prompt, try entering a value for the screen length with the **terminal length** command in EXEC mode. Command output is not paused if the **length** value is set to zero. The following example shows how to set the terminal length:

```
RP/0/RSP1/CPU0:router# terminal length 20
```

For information on searching or filtering CLI output, see the [“Filtering show Command Output”](#) section on page 5-9.

Halting the Display of Screen Output

To interrupt screen output and terminate a display, press Ctrl-C, as shown in the following example:

```
RP/0/RSP0/CPU0:router# show running-config
<Ctrl-C>
```

Redirecting Output to a File

By default, CLI command output appears on screen. CLI command output can be redirected to a user-specified file by entering a filename and location after the **show** command syntax. The following command syntax is used to redirect output to a file:

```
show command | file filename
```

This feature enables you to save any **show** command output in a file for further analysis and reference. When you choose to redirect command output, consider the following guidelines:

- If the full path of the file is not specified, the default directory for your account is used. You should always save your target configuration files to this location.
- If the saved output is to be used as a configuration file, the filename should end with the `cfg` suffix for easy identification. This suffix is not required, but can help locate target configuration files.

Example: `myconfig.cfg`

In the following example, a target configuration file is saved to the default user directory:

```
RP/0/RSP0/CPU0:router# configure
RP/0/RSP0/CPU0:router(config)# show configure | file disk0:myconfig.cfg
RP/0/RSP0/CPU0:router(config)# abort
RP/0/RSP0/CPU0:router#
```

Narrowing Output from Large Configurations

Viewing a large running configuration can produce thousands of lines of output. To limit the output of a **show** command to only the items you want to view, use the procedures in the following sections:

- [Limiting show Command Output to a Specific Feature or Interface, page 5-8](#)
- [Using Wildcards to Display All Instances of an Interface, page 5-8](#)

Limiting show Command Output to a Specific Feature or Interface

Entering keywords and arguments in the **show** command limits the **show** output to a specific feature or interface.

In the following example, only information about the static IP route configuration appears:

```
RP/0/RSP1/CPU0:router# show running-config router static

router static
  address-family ipv4 unicast
    0.0.0.0/0 10.21.0.1
    0.0.0.0/0 Gi0/1/0/1 10.21.0.1
  !
!
```

In the following example, the configuration for a specific interface appears:

```
RP/0/RSP0/CPU0:router# show running-config interface Gi 0/1/0/1

interface Gi0/1/0/1
  ipv4 address 10.21.54.31 255.255.0.0
  !
```

Using Wildcards to Display All Instances of an Interface

To display the configuration for all instances, type the asterisk (*) wildcard character.



Note

See the [“Using Wildcards to Identify Interfaces in show Commands”](#) section on page 5-12 for more information.

In the following example, a configuration for all Gigabit-Ethernet interfaces appears:

```
RP/0/RSP1/CPU0:router# show running-config interface gi *

interface Gi0/1/0/0
  ipv4 address 10.2.3.4 255.255.255.0
  gi
    crc 32
  !
  shutdown
  keepalive disable
  !
interface Gi0/1/0/1
  ipv4 address 10.2.3.5 255.255.255.0
  gi
    crc 32
  !
  shutdown
  keepalive disable
  !
interface Gi0/1/0/2
  ipv4 address 10.2.3.6 255.255.255.0
  gi
    crc 32
  !
  shutdown
  keepalive disable
  !
interface Gi0/1/0/3
  ipv4 address 10.2.3.7 255.255.255.0
  gi
    crc 32
  !
  shutdown
  keepalive disable
  !

--More--
```

Filtering show Command Output

Output from the **show** commands can generate a large amount of data. To display only a subset of information, type the Pipe character (|) followed by a keyword (**begin**, **include**, **exclude**, or **file**) and a regular expression. [Table 5-3](#) shows the filtering options for the **show** command.

Table 5-3 show Command Filter Options

Command	Description
show <i>command</i> begin <i>regular-expression</i>	Begins unfiltered output of the show command with the first line that contains the regular expression.
show <i>command</i> exclude <i>regular-expression</i>	Displays output lines that do not contain the regular expression.
show <i>command</i> include <i>regular-expression</i>	Displays output lines that contain the regular expression.
show <i>command</i> file <i>device0:path/file</i>	Writes the output lines that contain the regular expression to the specified file on the specified device.

In the following example, the **show interface** command includes only lines in which the expression “protocol” appears:

```
RP/0/RSP0/CPU0:router# show interface | include protocol

Null0 is up, line protocol is up
0 drops for unrecognized upper-level protocol
Gi0/2/0/0 is administratively down, line protocol is administratively down
0 drops for unrecognized upper-level protocol
Gi0/2/0/1 is administratively down, line protocol is administratively down
0 drops for unrecognized upper-level protocol
Gi0/2/0/2 is administratively down, line protocol is administratively down
0 drops for unrecognized upper-level protocol
Gi0/2/0/3 is administratively down, line protocol is administratively down
0 drops for unrecognized upper-level protocol
MgmtEthernet0/RSP0/CPU0/0 is administratively down, line protocol is administratively
down
MgmtEthernet0/RSP0/CPU0/0 is administratively down, line protocol is administratively
down
0 drops for unrecognized upper-level protocol
```

**Note**

Filtering is available for submodes, complete commands, and anywhere that <cr> appears in the “?” output.

Adding a Filter at the --More-- Prompt

You can specify a filter at the **--More--** prompt of a **show** command output by entering a forward slash (/) followed by a regular expression. The filter remains active until the command output finishes or is interrupted (using Ctrl-Z or Ctrl-C). The following rules apply to this technique:

- If a filter is specified at the original command or previous **--More--** prompt, a second filter cannot be applied.
- The use of the keyword **begin** does not constitute a filter.
- The minus sign (-) preceding a regular expression displays output lines that do not contain the regular expression.
- The plus sign (+) preceding a regular expression displays output lines that contain the regular expression.

In the following example, the user adds a filter at the **--More--** prompt to show only the lines in the remaining output that contain the regular expression “ip.”

```
RP/0/RSP0/CPU0:router# show configuration running | begin line

Building configuration...
line console
  exec-timeout 120 120
!
logging trap
--More--
/ip
filtering...
ip route 0.0.0.0 255.255.0.0 Gi0/2/0/0
interface Gi0/2/0/0
  ip address 172.19.73.215 255.255.0.0
end
```

**Tip**

On most systems, Ctrl-Z can be entered at any time to interrupt the output and return to EXEC mode.

For more information, see [Appendix A, “Understanding Regular Expressions, Special Characters, and Patterns.”](#)

Multipipe Support

The multipipe feature supports the multiple pipes on the command-line interface. With this feature the output can be processed by an enhanced utility set. Using various combination of utilities, it is possible to gather, filter, and format the output of any **show** command. An arbitrary limit of 8 pipes is supported on command-line interface with this limit superseded by the limit of characters that can be typed on the single line (1024) if the individual commands specified with pipes are long enough.

In addition, if you want to give the Pipe character (|) as a pattern, you must give it in double quotes. For example:

```
RP/0/RP1/CPU0:single8-hfr# show running-config|include "gi|ospf"|file disk0:/usr/a.log
```

Show Parser Dump Enhancement Feature

The **show parser dump** command displays the CLI syntax options for a specific submode.

It is a utility that dumps the parser commands supported on the router and a tool that displays line-by-line commands available in a submode. The command is available in every mode and it shows the command set available for that mode. This is a very handy tool for collecting the CLI commands for a mode.

The **show parser dump** command supports a filters. Specify an initial portion of the command, then matching commands display.

```
RP/0/RSP1/CPU0:router(config-un)# show parser dump
```

```
show
show configuration merge
show configuration running sanitized desanitize rpl
show configuration running sanitized
show configuration running
show configuration
show configuration failed noerrors
show configuration failed
show configuration failed load
show running-config
show running-config sanitized desanitize rpl
show running-config sanitized
show running-config submode
show parser dump
show history detail
show history
pwd
exit
```

Wildcards, Templates, and Aliases

This section contains the following topics:

- [Using Wildcards to Identify Interfaces in show Commands, page 5-12](#)
- [Creating Configuration Templates, page 5-13](#)
- [Aliases, page 5-16](#)
- [Keystrokes Used as Command Aliases, page 5-17](#)

Using Wildcards to Identify Interfaces in show Commands

Wildcards (*) identify a group of interfaces in **show** commands. [Table 5-4](#) provides examples of wildcard usage to identify a group of interfaces.

Table 5-4 Examples of Wildcard Usage

Wildcard Syntax	Description
*	Specifies all interfaces
gi*	Specifies all Gigabit-Ethernet interfaces in the system
gi0/1/*	Specifies all Gigabit-Ethernet interfaces in rack 0, slot 1
gi0/3/4.*	Specifies all subinterfaces for Gi0/3/4



Note

The wildcard (*) must be the last character in the interface name.

Example

In the following example, the configuration for all Gigabit-Ethernet interfaces in rack 0, slot 1 appears:

```
RP/0/RSP1/CPU0:router# show running-config interface Gi0/1/*
```

```
interface Gi0/1/0/0
  ipv4 address 10.2.3.4 255.255.255.0
  gi
  crc 32
  !
  keepalive disable
interface Gi0/1/0/1
  ipv4 address 10.2.3.5 255.255.255.0
  gi
  crc 32
  !
  keepalive disable
interface Gi0/1/0/2
  ipv4 address 10.2.3.6 255.255.255.0
  gi
  crc 32
  !
  keepalive disable
```

```

interface Gi0/1/0/3
  ipv4 address 10.2.3.7 255.255.255.0
  gi
    crc 32
  !
  keepalive disable

```

--More--

In the following example, the state of all Gigabit-Ethernet interfaces appears:

```
RP/0/RSP1/CPU0:router# show interfaces gi* brief
```

Intf Name	Intf State	LineP State	Encap Type	MTU (byte)	BW (Kbps)
Gi0/1/0/0	up	up	HDLC	4474	2488320
Gi0/1/0/1	up	up	HDLC	4474	2488320
Gi0/1/0/2	up	up	HDLC	4474	2488320
Gi0/1/0/3	up	up	HDLC	4474	2488320
Gi0/1/0/4	up	up	HDLC	4474	2488320
Gi0/1/0/5	up	up	HDLC	4474	2488320
Gi0/1/0/6	up	up	HDLC	4474	2488320
Gi0/1/0/7	up	up	HDLC	4474	2488320
Gi0/1/0/8	up	up	HDLC	4474	2488320
Gi0/1/0/9	up	up	HDLC	4474	2488320
Gi0/1/0/10	up	up	HDLC	4474	2488320
Gi0/1/0/11	up	up	HDLC	4474	2488320
Gi0/1/0/12	up	up	HDLC	4474	2488320
Gi0/1/0/13	up	up	HDLC	4474	2488320
Gi0/1/0/14	up	up	HDLC	4474	2488320
Gi0/1/0/15	up	up	HDLC	4474	2488320

Creating Configuration Templates

Configuration templates allow you to create a name that represents a group of configuration commands. After a template is defined, it can be applied to interfaces by you or other users. As networks scale to large numbers of nodes and ports, the ability to configure multiple ports quickly using templates can greatly reduce the time it takes to configure interfaces.

The two primary steps in working with templates are creating templates and applying templates. The following procedure describes how to create a configuration template.

SUMMARY STEPS

1. **configure**
2. **template** *template-name* [(\$parameter \$parameter...)] [*config-commands*]
3. Type the template commands.
4. **end-template**
5. **commit**
6. **show running-config template** *template-name*

DETAILED STEPS

	Command or Action	Purpose
Step 1	configure Example: Router# configure	Enters global configuration mode.
Step 2	template <i>template-name</i> [(<i>\$parameter</i> <i>\$parameter...</i>)] [<i>config-commands</i>] Example: RP/0/RSP0/CPU0:router(config)# template tmplt_1	Enters template configuration mode and creates a template. <ul style="list-style-type: none"> <i>template-name</i>: Unique name for the template to be applied to the running configuration. <i>parameter</i>: (Optional) Actual values of the variables specified in the template definition. Up to five parameters can be specified within parentheses. Each parameter must begin with the \$ character. Templates can be created with or without parameters. <i>config-commands</i>: (Optional) Global configuration commands to be added to the template definition. Any name in a command (such as the server name, group name, and so on) can be parameterized. This means that those parameters can be used in the template commands (starting with \$) and replaced with real arguments when applied. To remove the template, use the no form of this command.
Step 3	Type the template commands. Example: RP/0/RSP0/CPU0:router(config-TPL)# hostname test	Defines the template commands.
Step 4	end-template Example: RP/0/RSP0/CPU0:router(config-TPL)# end-template	Ends the template definition session and exits template configuration mode. <ul style="list-style-type: none"> When you end the template session, you are returned to global configuration mode.
Step 5	commit Example: RP/0/RSP0/CPU0:router(config-TPL)# commit	Applies the target configuration commands to the running configuration.
Step 6	show running-config template <i>template-name</i> Example: RP/0/RSP0/CPU0:router# show running-config template tmplt_1	Displays the details of the template.

Examples

In the following example, a simple template is defined. The template contents are then displayed with the **show running-config template** *template-name* command:

```
RP/0/RSP0/CPU0:router# configure
RP/0/RSP0/CPU0:router(config)# template jbstest
RP/0/RSP0/CPU0:router(config-TPL)# hostname test
RP/0/RSP0/CPU0:router(config-TPL)# end-template
RP/0/RSP0/CPU0:router(config)# commit
RP/0/RSP0/CPU0:router(config)# show running-config template jbstest

template jbstest
  hostname test
end-template
```

In the next example, a template is defined, and the template requires a parameter. The template contents are then displayed with the **show running-config template** *template-name* command:

```
RP/0/RSP0/CPU0:router# configure
RP/0/RSP0/CPU0:router(config)# template test2 (hostname)
RP/0/RSP0/CPU0:router(config-TPL)# hostname $hostname
RP/0/RSP0/CPU0:router(config-TPL)# end-template
RP/0/RSP0/CPU0:router(config)# commit
RP/0/RSP0/CPU0:router(config)# show running-config template test2

template test2 (hostname )
  hostname $hostname
end-template
```

Applying Configuration Templates

To apply a template, type the **apply-template** *template-name* [(*parameter*)] command in global configuration mode and consider the following guidelines:

- Only one template can be applied at a time.
- If the same template is applied multiple times, the most recent application overwrites the previous ones.
- Provide the exact number of parameters for the template.
- Templates are applied as a “best effort” operation; only valid changes are committed. If any command in the template fails, that command is discarded.
- After a template is applied, the **show configuration** command displays the target configuration changes. The target configuration must be committed (with the **commit** command) to become part of the running configuration.

Examples

In the following example, a simple template is defined. The template contents are then displayed with the **show running-config template** *template-name* command:

```
RP/0/RSP0/CPU0:router# configure
RP/0/RSP0/CPU0:router(config)# apply-template jbstest
RP/0/RSP0/CPU0:router(config)# show running-config template jbstest

Building configuration...
```

```
hostname test
end
```

In the next example, a template with one parameter is applied and the `show configuration` command displays the result:

```
RP/0/RSP0/CPU0:router# configure
RP/0/RSP0/CPU0:router(config)# apply-template test2 (router)
RP/0/RSP0/CPU0:router(config)# show configuration

Building configuration...
hostname router
end
```

Aliases

Cisco IOS XR software lets you define command line aliases for any physical or logical entity in a router. After you define the alias, it can be used in the CLI to reference the real entity.

To create a command alias, type the `alias` command in global configuration or administration configuration mode:

```
alias alias-name [(parameter1 parameter2...)] command-syntax [$parameter1] [command-syntax [$parameter2]]
```

Table 5-5 defines the `alias` command syntax.

Table 5-5 *alias* Command Syntax

Syntax	Specifies that the Alias Is Created for
<i>alias-name</i>	Name of the command alias. An alias name can be a single word or multiple words joined by a dash (-).
<i>command-syntax</i>	Original command syntax. Valid abbreviations of the original command syntax can be entered for the <i>command-syntax</i> argument.
(<i>parameterx</i>)	Argument or keyword that belongs to the command you specified for the <i>command-syntax</i> argument. When the parameter is entered in parenthesis after the alias name, the alias requires a parameter name. To associate the parameter with a command within the alias, type the \$ character preceding the parameter name.

Multiple commands can be supported under a single command alias, and multiple variables can be supported for each command. If multiple commands are specified under a single alias, then each command is executed in the order in which it is listed in the `alias` command.

In the following example, an alias named `my-cookie` is created for the Management Ethernet interface, and then the new alias is specified to enter interface configuration mode:

```
RP/0/RSP0/CPU0:router(config)# alias my-cookie mgmtEth 0/0/CPU0/0

RP/0/RSP0/CPU0:router(config)# interface my-cookie
RP/0/RSP0/CPU0:router(config)# interface mgmtEth 0/0/CPU0/0
RP/0/RSP0/CPU0:router(config-if)#
```

After you enter a command with an alias, the router displays the command you entered with the alias value so that you can verify that alias value.

To delete a specific alias, type the **no** form of the **alias** command with the alias name.

Keystrokes Used as Command Aliases

The system can be configured to recognize particular keystrokes (key combination or sequence) as command aliases. In other words, a keystroke can be set as a shortcut for executing a command. To enable the system to interpret a keystroke as a command, use the Ctrl-V or Esc, Q key combination before entering the command sequence.

Command History

The Cisco IOS XR software lets you display a history of the most recently entered and deleted commands. You can also redisplay the command line while a console message is being shown. The following sections describe the command history functionality:

- [Viewing Previously Entered Commands, page 5-17](#)
- [Recalling Previously Entered Commands, page 5-17](#)
- [Recalling Deleted Entries, page 5-18](#)
- [Redisplaying the Command Line, page 5-18](#)



Note

To roll back to a previously committed configuration, see the “[Managing Configuration History and Rollback](#)” section on page 4-6.

Viewing Previously Entered Commands

The Cisco IOS XR software records the ten most recent commands issued from the command line in its history buffer. This feature is particularly useful for recalling long or complex commands or entries, including access lists.

To display commands from the history buffer, type the **show history** command as follows:

```
RP/0/RSP0/CPU0:router# show history

show configuration history commit
show configuration commit list
sho config commit changes 1000000001
show history
```

Recalling Previously Entered Commands

The Cisco IOS XR software records the ten most recent commands issued from the command line in its history buffer. This feature is particularly useful for recalling long or complex commands or entries, including access lists.

To recall commands from the history buffer, use one of the commands or key combinations listed in [Table 5-6](#).

Table 5-6 *Command History*

Command or Key Combination	Purpose
Ctrl-P or the up arrow key	Recalls commands in the history buffer, beginning with the most recent command. Repeat the key sequence to recall successively older commands.
Ctrl-N or the down arrow key	Returns to more recent commands in the history buffer after recalling commands with Ctrl-P or the up arrow key. Repeat the key sequence to recall successively more recent commands.

Recalling Deleted Entries

The Cisco IOS XR CLI also stores deleted commands or keywords in a history buffer. The buffer stores the last ten items that have been deleted using Ctrl-K, Ctrl-U, or Ctrl-X. Individual characters deleted using Backspace or Ctrl-D are not stored.

[Table 5-7](#) identifies the keystroke combinations used to recall deleted entries to the command line.

Table 5-7 *Keystroke Combinations to Recall Deleted Entries*

Command or Key Combination	Recalls
Ctrl-Y	The most recent entry in the buffer (press the keys simultaneously).
Esc, Y	The previous entry in the history buffer (press the keys sequentially).



Note

The Esc, Y key sequence does not function unless the Ctrl-Y key combination is pressed first. If the Esc, Y is pressed more than ten times, the history cycles back to the most recent entry in the buffer.

Redisplaying the Command Line

If the system sends a message to the screen while a command is being entered, the current command line entry can be redisplayed using the Ctrl-L or Ctrl-R key combination.

Key Combinations

The following sections provide information on key combinations:

- [Key Combinations to Move the Cursor](#), page 5-19
- [Keystrokes to Control Capitalization](#), page 5-19
- [Keystrokes to Delete CLI Entries](#), page 5-20
- [Transposing Mistyped Characters](#), page 5-20

Key Combinations to Move the Cursor

Table 5-8 shows the key combinations or sequences you can use to move the cursor around on the command line to make corrections or changes. When you use cursor control keys, consider the following guidelines:

- Ctrl indicates the Control key, which must be pressed simultaneously with its associated letter key.
- Esc indicates the Escape key, which must be pressed first, followed by its associated letter key.
- Keys are not case sensitive.

Table 5-8 Key Combinations Used to Move the Cursor

Keystrokes	Function	Moves the Cursor
Left arrow or Ctrl-B	Back character	One character to the left. When you enter a command that extends beyond a single line, you can press the left arrow or Ctrl-B keys repeatedly to scroll back toward the system prompt and verify the beginning of the command entry, or you can press the Ctrl-A key combination.
Right arrow or Ctrl-F	Forward character	One character to the right.
Esc, B	Back word	Back one word.
Esc, F	Forward word	Forward one word.
Ctrl-A	Beginning of line	To the beginning of the line.
Ctrl-E	End of line	To the end of the command line.

Keystrokes to Control Capitalization

Letters can be uppercase or lowercase using simple key sequences. Table 5-9 describes the keystroke combinations used to control capitalization.



Note

Cisco IOS XR commands are generally case insensitive and typically all in lowercase.

Table 5-9 Keystrokes Used to Control Capitalization

Keystrokes	Purpose
Esc, C	Makes the letter at the cursor uppercase.
Esc, L	Changes the word at the cursor to lowercase.
Esc, U	Makes letters from the cursor to the end of the word uppercase.

Keystrokes to Delete CLI Entries

Table 5-10 describes the keystrokes used to delete command-line entries.

Table 5-10 Keystrokes for Deleting Entries

Keystrokes	Deletes
Delete or Backspace	The character to the left of the cursor.
Ctrl-D	The character at the cursor.
Ctrl-K	All characters from the cursor to the end of the command line.
Ctrl-U or Ctrl-X	All characters from the cursor to the beginning of the command line.
Ctrl-W	The word to the left of the cursor.
Esc, D	From the cursor to the end of the word.

Transposing Mistyped Characters

To transpose mistyped characters, use the Ctrl-T key combination.



CHAPTER 6

Troubleshooting the Cisco IOS XR Software

This chapter offers tools and procedures that identify the source of hardware and software problems. This chapter also provides instructions on gathering data for further analysis by Cisco customer support .

Contents

- [Additional Sources for Information, page 6-1](#)
- [Basic Troubleshooting Commands, page 6-2](#)
- [Configuration Error Messages, page 6-6](#)
- [Memory Warnings in Configuration Sessions, page 6-7](#)
- [Interfaces Not Coming Up, page 6-12](#)

Additional Sources for Information

For additional information on troubleshooting, see the following sources:

- If the Cisco IOS XR Software does not start and display the EXEC mode prompt, see *Cisco ASR 9000 Series Aggregation Services Router ROM Monitor Guide*.
- The Cisco Technical Assistance Center (Cisco TAC) home page, containing 30,000 pages of searchable technical content, including links to products, technologies, solutions, technical tips, and tools. Registered Cisco.com users can log in from this page to access even more content.
<http://www.cisco.com/public/support/tac/home.shtml>
- The “Conventions” section on page xii.

Basic Troubleshooting Commands

The following sections describe some basic techniques used to determine connectivity to another device and display information on the configuration and operation of a router.

- [Using show Commands to Display System Status and Configuration, page 6-2](#)
- [Using the ping Command, page 6-2](#)
- [Using the traceroute Command, page 6-3](#)
- [Using debug Commands, page 6-3](#)

Using show Commands to Display System Status and Configuration

Use **show** commands to check the status of various Cisco IOS XR software subsystems and services. [Table 5-2](#) lists some of the common **show** commands.

Using the ping Command

Use the **ping** command to diagnose network connectivity. In EXEC mode, enter a hostname or an IP address as an argument to this command. In administration EXEC mode, you can use the fabric or the control Ethernet network to ping other nodes.

The **ping** command sends an echo request packet to a destination, then awaits a reply. Ping output can help you evaluate path-to-destination reliability, delays over the path, and whether the destination can be reached or is functioning.

Each exclamation point (!) indicates receipt of a reply. A period (.) indicates the network server timed out while waiting for a reply. Other characters may appear in the ping output display, depending on the protocol type.

Examples

In the following example, a successful ping attempt is shown:

```
RP/0/RSP0/CPU0:router# ping 10.233.233.233

Type escape sequence to abort.
Sending 5, 100-byte ICMP Echos to 10.233.233.233, timeout is 2 seconds:
!!!!
Success rate is 100 percent (5/5), round-trip min/avg/max = 1/2/7 ms
```

In the next example, an unsuccessful ping attempt is shown:

```
RP/0/RSP0/CPU0:router# ping 10.1.1.1

Type escape sequence to abort.
Sending 5, 100-byte ICMP Echos to 10.1.1.1, timeout is 2 seconds:
.....
Success rate is 0 percent (0/5)
```

The following example shows the output of ping through the fabric:

```
RP/0/RSP1/CPU0:router(admin)# ping fabric location 0/6/5

Src node:          529 : 0/RSP1/CPU0
Dest node:         109 : 0/6/5
Local node:        529 : 0/RSP1/CPU0
Packet cnt:        1 Packet size: 128 Payload ptn type: default (0)
Hold-off (ms):    300 Time-out(s): 2 Max retries: 5

Running Fabric node ping.
Please wait...
Src: 529:, Dest: 109, Sent: 1, Rec'd: 1, Mismatched: 0
Min/Avg/Max RTT: 20000/20000/20000
Fabric node ping succeeded for node: 109
```

Using the traceroute Command

Use the **traceroute** command in EXEC mode to discover the routes that packets take when traveling to their destination. Enter a hostname or an IP address as an argument to this command.

This command works by taking advantage of the error messages generated by routers when a datagram exceeds its time-to-live (TTL) value.

The **traceroute** command starts by sending probe datagrams with a TTL value of 1, causing the first router to discard the probe datagram and send back an error message. The **traceroute** command sends several probes at each TTL level and displays the round-trip time for each.

The **traceroute** command sends one probe at a time. Each outgoing packet may result in one or two error messages. A *time exceeded* error message indicates that an intermediate router has seen and discarded the probe. A *destination unreachable* error message indicates that the destination node has received the probe and discarded it because it could not deliver the packet. If the timer times out before a response comes in, the **traceroute** command prints an asterisk (*).

The **traceroute** command terminates when the destination responds, the maximum TTL is exceeded, or the user interrupts the trace with the escape sequence.

Examples

In the following example, the route for an IP address appears:

```
RP/0/RSP0/CPU0:router# traceroute 10.233.233.233

Type escape sequence to abort.
Tracing the route to 10.233.233.233

 0 172.25.0.2 11 msec 2 msec 1 msec
 1 192.255.254.254 1 msec * 2 msec
```

Using debug Commands

Debug commands are used to diagnose and resolve network problems. Use **debug** commands to troubleshoot specific problems or during troubleshooting sessions.

Use **debug** commands to turn on or off debugging for a specific service or subsystem. When debugging is turned on for a service, a debug message is generated each time the debugging code section is entered.

The following sections provide information on debugging:

- [Viewing a List of Debug Features, page 6-4](#)
- [Enabling Debugging for a Feature, page 6-5](#)
- [Viewing Debugging Status, page 6-5](#)
- [Disabling Debugging for All Services Started at the Active Terminal Session, page 6-6](#)
- [Disabling Debugging for All Services Started at All Terminal Sessions, page 6-6](#)



Caution

Debug commands can generate a very large amount of output and can render the system unusable. Use **debug** to troubleshoot specific problems or during specific troubleshooting sessions on systems that are not in production.

Viewing a List of Debug Features

To display a list of the available debug features, Type the debug mode and enter a ? for on-screen help. The set of debug mode features is different in EXEC and administration EXEC modes. In the following example, EXEC mode is the entry point to debug mode:

```
RP/0/RSP0/CPU0:router# debug
RP/0/RSP0/CPU0:router(debug)# ?

aaa                AAA Authentication, Authorization and Accounting
adjacency          Adjacency debug
adjacency          platform AIB information
aib                AIB information
alarm-logger       Turn on alarm debugging
arm                IP Address Repository Manager
arp                IP ARP transactions
asic-errors        Debug ASIC errors
asic-scan          Debug Asic Scan
--More--
```

In the next example, administration EXEC mode is the entry point to debug mode:

```
RP/0/RSP1/CPU0:router# admin
RP/0/RSP1/CPU0:router(admin)# debug
RP/0/RSP1/CPU0:router(admin-debug)# ?

cctl               Chassis control driver process debug
cetftp             Control ethernet TFTP (CE-TFTP) server process debug
cpuctrl           Debug Cpuctrl Driver
describe           Describe a command without taking real actions
diagnostic         Diagnostic debugging
dsc                dsc debug: all, fsm, table, cfg, and api
dumper            Admin Debug Dumper
exit              Exit from this submode
fabric             Fabric debugging
fabricq           Debug Fabric Queue Manager
fia               Debug the Fabric Interface ASIC (FIA) driver
gsp               Admin Debug gsp
ingressq          Debug Ingress Queue Manager
install           Install debug information
inv               Inventory manager process debug
invd              Inventory debug: all, trap, dll mem
invmgr            Inventory Manager client API interface debug
ntp               NTP information
oird              oird all, event, message
pair              DRP Pairing debug: Display debugging messages of drp_pairing
```

```
shelfmgr      Shelfmgr debug: all, heartbeat, boot, fsm, init and eah
sysdb         Configure SysDB debug settings
upgrade-fpd   Debug upgrade fpd
--More--
```

Enabling Debugging for a Feature

To enable debugging for a feature, type the **debug** command in EXEC or administration EXEC mode and then enable the feature for debugging. For example:

```
RP/0/RSP0/CPU0:router# debug
RP/0/RSP0/CPU0:router(debug)# aaa all
RP/0/RSP0/CPU0:router(debug)# exit
```

You can also type the complete command from EXEC mode, as shown in the following example:

```
RP/0/RSP0/CPU0:router# debug aaa all
```

Viewing Debugging Status

Type the **show debug** command to display the debugging features enabled for your terminal session. The terminal session is labeled *tty* and represents your connection to the router through a specific port, which might be the console port, auxiliary port, or Management Ethernet interface. In the following example, the command display indicates that debugging is enabled for two features (AAA and ipv4 io icmp) from a terminal session on the console port of RSP1:

```
RP/0/RSP0/CPU0:router# show debug

#### debug flags set from tty 'con0_RSP1_CPU0' ####
aaa all flag is ON
ipv4 io icmp flag is ON

RP/0/RSP0/CPU0:router# no debug aaa all
RP/0/RSP0/CPU0:router# show debug

#### debug flags set from tty 'con0_RSP1_CPU0' ####
ipv4 io icmp flag is ON
```

The preceding example is for a Cisco CRS-1 router. On a Cisco XR 12000 Series Router, the slot number of the tty ID is 0 or 1 instead of RSP0 or RSP1.

Type the **show debug conditions** command to display the conditional debugging status. For example:

```
RP/0/RSP0/CPU0:router# show debug conditions

#### debug conditions set from tty 'con0_RSP1_CPU0' ####
interface condition is ON for interface 'gi0/2/0/1'
```

Disabling Debugging for a Service

Use the **no** form of the **debug** command or the **undebug** command to turn off debugging for a service or subsystem.

In the following example, the **no debug** command disables debugging for the AAA feature:

```
RP/0/RSP0/CPU0:router# no debug aaa all
RP/0/RSP0/CPU0:router# show debug

#### debug flags set from tty 'con0_RSP1_CPU0' ####
ipv4 io icmp flag is ON
```

You can also turn off debugging from the `undebug` mode, as shown in the following example:

```
RP/0/RSP0/CPU0:router# undebug
RP/0/RSP0/CPU0:router(undebug)# aaa all
RP/0/RSP0/CPU0:router(undebug)# exit
```

Disabling Debugging for All Services Started at the Active Terminal Session

Use the `undebug all` or `no debug all` command to turn off all debugging started by the active terminal session. For example, if you enter either of these commands while connected to the router through the console port on the active RP, all debug sessions started from that console port are disabled. In the following example, debugging for all services is disabled and then verified:

```
RP/0/RSP0/CPU0:router# undebug all
RP/0/RSP0/CPU0:router# show debug
```

No matching debug flags set

Disabling Debugging for All Services Started at All Terminal Sessions

Use the `undebug all all-tty` command to turn off debugging for all services that have been started from all terminal sessions. For example if you enter this command while connected to the router through the console port on the active RP, all debug sessions started from all ports are disabled. In the following example, debugging for all services and ports is disabled and then verified:

```
RP/0/0/CPU0:router# undebug all all-tty
RP/0/0/CPU0:router# show debug
```

No matching debug flags set

Configuration Error Messages

The following sections contain information on configuration error messages:

- [Configuration Failures During a Commit Operation, page 6-6](#)
- [!Configuration Errors at Startup, page 6-7](#)

Configuration Failures During a Commit Operation

A target configuration is added to the running configuration of a router when the `commit` command is entered. During this operation, the changes are automatically verified by the other components in the system. If successful, the configuration becomes part of the running configuration. If some configuration items fail, an error message is returned.

To display the configuration items that failed and see the cause of each failure, type the `show configuration failed` command.



Note

The `show configuration failed` command can be entered in either the EXEC mode or any configuration mode. In any mode, the configuration failures from the most recent `commit` operation are displayed.

In the following example, a configuration error occurs when an invalid commit operation is attempted:

```
RP/0/RP0/CPU0:router# configure
RP/0/RP0/CPU0:router(config)# taskgroup alr
RP/0/RP0/CPU0:router(config-tg)# description this is an example of an invalid task group
RP/0/RP0/CPU0:router(config-tg)# commit
```

```
% Failed to commit one or more configuration items. Please use 'show configuration failed'
to view the errors
```

!To display the configuration items that failed, including a description of the error, type the **show configuration failed** command:

```
P/0/RSP0/CPU0:router(config-tg)# show configuration failed
```

```
!! CONFIGURATION FAILED DUE TO SEMANTIC ERRORS
```

```
taskgroup alr
```

```
!!% Usergroup/Taskgroup names cannot be taskid names
```

You can also display the failed configuration items without the error description by entering the **show configuration failed noerror** command:

```
!! CONFIGURATION FAILED DUE TO SEMANTIC ERRORS
```

```
taskgroup alr
```

! Configuration Errors at Startup

Configuration errors that occurred during system startup can be displayed with the **show configuration failed startup** command. For example:

```
RP/0/RSP0/CPU0:router# show configuration failed startup
```

```
!! CONFIGURATION FAILED DUE TO SYNTAX ERRORS
```

```
ntp
http server
```

Memory Warnings in Configuration Sessions

The Cisco IOS XR software automatically monitors and manages the system resources in a router. Under normal operating conditions, memory problems should not occur.

When a low-memory issue does occur, it is often in the form of a low-memory warning during a configuration session. Low-memory conditions can be caused by multiple, large configurations being added to the router at a single time. Users can remove the source of a problem by removing configurations.

The following sections describe the commands used to display memory usage in a router and what to do if a low-memory warning appears:

- [Understanding Low-Memory Warnings in Configuration Sessions, page 6-8](#)
- [Viewing System Memory Information, page 6-9](#)
- [Removing Configurations to Resolve Low-Memory Warnings, page 6-10](#)
- [Contacting TAC for Additional Assistance, page 6-11](#)

Understanding Low-Memory Warnings in Configuration Sessions

The Cisco IOS XR software monitors memory usage in the Cisco CRS-1 router. If system memory becomes low, an error message appears when you attempt to enter configuration mode.

An “out-of-memory” error message appears during one of the following situations:

- When a user attempts to enter configuration mode.
- During a configuration session when the memory shortage occurs.
- When a user attempts to load a target configuration from a large file that results in a memory shortage.
- During a commit operation that results in the low-memory warning message. The commit operation is denied and only lr-root users can perform commit operations to remove configurations.



Caution

Never ignore a low-memory warning. These warnings indicate a memory state that could affect system operations if not addressed.

“WARNING! MEMORY IS IN MINOR STATE”

If the system memory begins to run low, the following minor memory warning appears when you enter a new configuration mode.

```
WARNING! MEMORY IS IN MINOR STATE
```

Although users are allowed to enter configuration mode, they should immediately reduce memory usage using the tools described in the [“Removing Configurations to Resolve Low-Memory Warnings” section on page 6-10](#).

Failure to take action can result in a worsening situation and eventual impact to router operations.

“ERROR! MEMORY IS IN SEVERE (or CRITICAL) STATE”

When the memory is in a severe or critical state, router operation and performance is likely to be affected. Regular users are not allowed to enter configuration mode. Only lr-root owners can enter configuration mode to free memory by removing configurations.

In some situations, the **commit** command is not allowed. Users with lr-root access can still use the **commit force** command to apply configurations that reduce memory usage. Reducing memory usage normally means removing configurations, but a user can also add configurations that reduce memory usage. For example, configuring the **shutdown** command on an interface could cause numerous routes to be purged from the Routing Information Base (RIB), and Forwarding Information Base (FIB) configurations.

**Caution**

The **commit force** command should be used only to apply configurations that reduce memory usage. Adding configurations that increase memory usage could result in serious loss of router operation.

Viewing System Memory Information

To display a high level summary of system memory, type the **show memory summary** command. describes the meaning of each heading.

```
RP/0/RSP0/CPU0:router# show memory summary
```

```
Physical Memory: 2048M total
Application Memory : 1787M (1509M available)
Image: 132M (bootram: 132M)
Reserved: 128M, IOMem: 0, flashfsys: 0
Total shared window: 0
RP/0/RSP1/CPU0:router#
```

To display general memory usage for the device as a whole and by process, type the **show memory** command. describes the meaning of each heading.

```
RP/0/RSP0/CPU0:router# show memory
```

```
Physical Memory: 2048M total
Application Memory : 1787M (1510M available)
Image: 132M (bootram: 132M)
Reserved: 128M, IOMem: 0, flashfsys: 0
Total shared window: 0
```

```
kernel: jid 1
```

```
Address      Bytes      What
000d2000    12288     Program Stack
00112000    12288     Program Stack
Total Allocated Memory: 0
Total Shared Memory: 0
```

```
pkg/bin/wd-mpi: jid 72
```

```
Address      Bytes      What
4817f000     4096     Program Stack (pages not allocated)
48180000    516096   Program Stack (pages not allocated)
481fe000     8192     Program Stack
48200000     8192     Program Text
--More--
```

Table 6-1 *Heading Descriptions for show memory Command Output*

Heading	Description
Physical Memory	Amount of physical memory installed on the device.
Application Memory	Memory available for the system to use (total memory minus image size, reserved, IOMem, and flashfsys).
Image	Size of the bootable image.
Reserved	Reserved for packet memory.
IOMem	IO memory—Currently used as a backup for packet memory.
flashfsys	Flash file system memory.

Table 6-1 *Heading Descriptions for show memory Command Output*

Heading	Description
Process and JID	Process and job ID.
Address	Starting address in memory.
Bytes	Size of memory block.
What	Block description.

Removing Configurations to Resolve Low-Memory Warnings

To resolve most low-memory problems, you should remove the configurations from the router that are consuming the most memory. Often, memory problems occur when a large new configuration is added to the system. The following sections provide information to resolve low-memory issues:

- [Clearing a Target Configuration, page 6-10](#)
- [Removing Committed Configurations to Free System Memory, page 6-10](#)
- [Rolling Back to a Previously Committed Configuration, page 6-11](#)
- [Clearing Configuration Sessions, page 6-11](#)

Clearing a Target Configuration

A low-memory warning can occur when a large configuration file is loaded into a target configuration session. To remove the target configuration, type the **clear** command to discard the changes. For example:

```
RP/0/RSP0/CPU0:router(config)# clear
```



Caution

Committing a target configuration that has caused a low-memory warning can make the system unstable. Clearing a target configuration is a preventive measure to not let the system go into a worse memory state due to additional configuration. In addition, all other active configuration sessions can be closed to minimize the churn.

Removing Committed Configurations to Free System Memory

You can reduce memory usage by removing configurations from the router, as shown in the following procedure:

- Step 1** Type the **show memory summary** command in EXEC mode to display the overall system memory:

```
RP/0/RSP0/CPU0:router# show memory summary
```

```
Physical Memory: 2048M total
Application Memory : 1787M (1511M available)
Image: 132M (bootram: 132M)
Reserved: 128M, IOMem: 0, flashfsys: 0
Total shared window: 0
```

- Step 2** Type the **show configuration commit list** command in EXEC or administration EXEC mode to list the configurations you can remove.

**Note**

To display the details of a configuration, type the **show configuration commit changes** command followed by a commitID number. To display additional configuration history information, type the **show configuration history ?** command, and use the command options to display additional information.

- Step 3** Type the **show running-config** command to display the current configuration.
- Step 4** Remove configurations as needed to free memory.

For more information, see the [Managing Configuration History and Rollback, page 4-6](#).

Rolling Back to a Previously Committed Configuration

You can roll back the system to a previous committed configuration, as described in [Managing Configuration History and Rollback, page 4-6](#).

Clearing Configuration Sessions

Active configuration sessions and their associated target configurations can consume system memory. Users with the appropriate access privileges can display the open configuration sessions of other users and terminate those sessions, if necessary (see [Table 6-2](#)).

Table 6-2 Session Commands

Command	Description
show configuration sessions	Displays the active configuration sessions.
clear configuration sessions <i>session-id</i>	Clears a configuration session.

In the following example, the open configuration sessions are displayed with the **show configuration sessions** command. The **clear configuration sessions** command is then used to clear a configuration session.

```
RP/0/RSP0/CPU0:router# show configuration sessions

Session                Line      User      Date                Lock
00000211-002c409b-00000000  con0_RSP1_CPU0  UNKNOWN  Mon Feb  2 01:02:09 2004

RP/0/RSP0/CPU0:router# clear configuration sessions 00000211-002c409b-00000000

session ID '00000211-002cb09b-00000000' terminated
```

Contacting TAC for Additional Assistance

If you remove configurations and the low-memory condition remains, you may need to contact TAC for additional assistance. See the [“Additional Sources for Information”](#) section on page 6-1.

Interfaces Not Coming Up

The router interfaces are directly used in processing network traffic, so their status information is crucial to understanding how the device is functioning. This section contains information on the EXEC mode commands used to verify that the router interfaces are operational. The basic commands used in this process are summarized in [Table 6-3](#).

Table 6-3 *show interface Commands*

Command	Description
show interfaces	Displays detailed information about all interfaces installed or configured on the device, whether or not they are operational.
show interfaces type instance	Specifies a particular interface, rather than displaying information for all interfaces, as in the following example: <code>show interface gi0/1/0/0</code>
show ipv4 interface	Displays basic, IP-related information for all available interfaces.
show ipv4 interface brief	Quickly displays the most critical information about the interfaces, including the interface status (up or down) and the protocol status.

Verifying System Interfaces

Perform the following steps to verify the system interfaces.

- Step 1** Type the **show platform** command in administration EXEC to verify that all nodes are in the “IOS XR RUN” state:

```
RP/0/RSP0/CPU0:router(admin)# show platform
```

Node	Type	PLIM	State	Config State
0/1/SP	MSC (SP)	N/A	IOS XR RUN	PWR, NSHUT, MON
0/1/CPU0	MSC	160C48-POS/DPT	IOS XR RUN	PWR, NSHUT, MON
0/2/SP	MSC (SP)	N/A	IOS XR RUN	PWR, NSHUT, MON
0/2/CPU0	MSC	160C48-POS/DPT	IOS XR RUN	PWR, NSHUT, MON
0/3/SP	MSC (SP)	N/A	IOS XR RUN	PWR, NSHUT, MON
0/3/CPU0	MSC	160C48-POS/DPT	IOS XR RUN	PWR, NSHUT, MON
0/RSP0/CPU0	RP (Active)	N/A	IOS XR RUN	PWR, NSHUT, MON
0/RSP1/CPU0	RP (Standby)	N/A	IOS XR RUN	PWR, NSHUT, MON
0/SM0/SP	FC/S (SP)	N/A	IOS XR RUN	PWR, NSHUT, MON
0/SM1/SP	FC/S (SP)	N/A	IOS XR RUN	PWR, NSHUT, MON
0/SM2/SP	FC/S (SP)	N/A	IOS XR RUN	PWR, NSHUT, MON
0/SM3/SP	FC/S (SP)	N/A	IOS XR RUN	PWR, NSHUT, MON

- Step 2**

Type the **show ipv4 interface brief** command to verify IP address configuration and protocol status:

```
RP/0/RSP0/CPU0:router# show ipv4 interface brief
```

Interface	IP-Address	Status	Protocol
gi0/1/0/0	unassigned	Shutdown	Down
gi0/1/0/1	unassigned	Shutdown	Down
gi0/1/0/2	unassigned	Shutdown	Down
gi0/1/0/3	unassigned	Shutdown	Down
gi0/1/0/4	unassigned	Shutdown	Down
gi0/1/0/5	unassigned	Shutdown	Down
gi0/1/0/6	unassigned	Shutdown	Down

```

gi0/1/0/7                unassigned      Shutdown        Down
gi0/1/0/8                unassigned      Shutdown        Down
gi0/1/0/9                unassigned      Shutdown        Down
gi0/1/0/10               unassigned      Shutdown        Down
gi0/1/0/11               unassigned      Shutdown        Down
gi0/1/0/12               unassigned      Shutdown        Down
gi0/1/0/13               unassigned      Shutdown        Down
gi0/1/0/14               unassigned      Shutdown        Down
gi0/1/0/15               unassigned      Shutdown        Down
gi0/2/0/0                10.10.1.101    Down           Down
gi0/2/0/1                unassigned      Shutdown        Down
gi0/2/0/2                unassigned      Shutdown        Down
gi0/2/0/3                unassigned      Shutdown        Down
TenGigE0/3/0/0           unassigned      Shutdown        Down
TenGigE0/3/0/2           unassigned      Shutdown        Down
MgmtEth0/RSP0/CPU0/0    unassigned      Shutdown        Down

```

Step 3 Configure the interfaces, as shown in the following examples.



Note Type the **commit** command to make the new configuration part of the active running configuration. If you end the configuration session, you are automatically prompted to commit the changes, as shown in the second example:

```

RP/0/RSP0/CPU0:router# configure
RP/0/RSP0/CPU0:router(config)# interface gi0/2/0/1
RP/0/RSP0/CPU0:router(config-if)# ipv4 address 10.1.1.1 255.0.0.0
RP/0/RSP0/CPU0:router(config-if)# no shutdown
RP/0/RSP0/CPU0:router(config-if)# commit
RP/0/RSP0/CPU0:router(config-if)# end
RP/0/RSP0/CPU0:router#

RP/0/RSP0/CPU0:router# configure
RP/0/RSP0/CPU0:router(config)# interface gi0/2/0/2
RP/0/RSP0/CPU0:router(config-if)# ipv4 address 10.1.1.2 255.255.0.0
RP/0/RSP0/CPU0:router(config-if)# no shutdown
RP/0/RSP0/CPU0:router(config-if)# end
Uncommitted changes found, commit them? [yes]: yes
RP/0/RSP0/CPU0:router#

```

Step 4 Type the **show ipv4 interface brief** command to verify that the interfaces are “Up” in the Status column:

```

RP/0/RSP0/CPU0:router# show ipv4 interface brief

Interface                IP-Address      Status          Protocol
gi0/1/0/0                unassigned      Shutdown        Down
gi0/1/0/1                unassigned      Shutdown        Down
gi0/1/0/2                unassigned      Shutdown        Down
gi0/1/0/3                unassigned      Shutdown        Down
gi0/1/0/4                unassigned      Shutdown        Down
gi0/1/0/5                unassigned      Shutdown        Down
gi0/1/0/6                unassigned      Shutdown        Down
gi0/1/0/7                unassigned      Shutdown        Down
gi0/1/0/8                unassigned      Shutdown        Down
gi0/1/0/9                unassigned      Shutdown        Down
gi0/1/0/10               unassigned      Shutdown        Down
gi0/1/0/11               unassigned      Shutdown        Down
gi0/1/0/12               unassigned      Shutdown        Down
gi0/1/0/13               unassigned      Shutdown        Down
gi0/1/0/14               unassigned      Shutdown        Down
gi0/1/0/15               unassigned      Shutdown        Down
gi0/2/0/0                10.10.1.101    Up             Up

```

gi0/2/0/1	10.1.1.1	Up	Up
gi0/2/0/3	10.1.1.2	Shutdown	Down
gi0/2/0/3	unassigned	Shutdown	Down
TenGigE0/3/0/0	unassigned	Shutdown	Down
TenGigE0/3/0/2	unassigned	Shutdown	Down
MgmtEth0/RSP0/CPU0/0	unassigned	Shutdown	Down

Step 5 If the interface is in the “Shutdown/Down” state, as shown in the previous example, perform the following tasks:

- a. Verify that the status of the interface is “Shutdown”:

```
RP/0/RSP0/CPU0:router# show running-config interface gi0/2/0/3

interface gi0/2/0/3
 shutdown
 keepalive disable
!
```

- b. Bring the interface up with the following commands:

```
RP/0/RSP0/CPU0:router(config)# controller gi 0/2/0/3
RP/0/RSP0/CPU0:router(config-sonet)# no shutdown
RP/0/RSP0/CPU0:router(config-sonet)# commit
RP/0/RSP0/CPU0:router(config-sonet)# exit
RP/0/RSP0/CPU0:router(config)# interface gi 0/2/0/3
RP/0/RSP0/CPU0:router(config-if)# no shutdown
RP/0/RSP0/CPU0:router(config-if)# commit
RP/0/RSP0/CPU0:router(config-if)# end
RP/0/RSP0/CPU0:router#
```

Step 6 If the interface state is still displayed as “Down,” verify that the physical cable connections are correctly installed. The following message indicates that the interface has either a bad connection or no connection:

```
LC/0/0/1:Sep 29 15:31:12.921 : plim_4p_oc192[183]: %SONET-4-
ALARM : SONENT0_1_1_0: SLOS
```

Step 7 Verify again that the interface is up by entering the **show ipv4 interface brief** command:

```
RP/0/RSP0/CPU0:router# show ipv4 interface brief
```

Interface	IP-Address	Status	Protocol
gi0/1/0/0	unassigned	Shutdown	Down
gi0/1/0/1	unassigned	Shutdown	Down
gi0/1/0/2	unassigned	Shutdown	Down
gi0/1/0/3	unassigned	Shutdown	Down
gi0/1/0/4	unassigned	Shutdown	Down
gi0/1/0/5	unassigned	Shutdown	Down
gi0/1/0/6	unassigned	Shutdown	Down
gi0/1/0/7	unassigned	Shutdown	Down
gi0/1/0/8	unassigned	Shutdown	Down
gi0/1/0/9	unassigned	Shutdown	Down
gi0/1/0/10	unassigned	Shutdown	Down
gi0/1/0/11	unassigned	Shutdown	Down
gi0/1/0/12	unassigned	Shutdown	Down
gi0/1/0/13	unassigned	Shutdown	Down
gi0/1/0/14	unassigned	Shutdown	Down
gi0/1/0/15	unassigned	Shutdown	Down
gi0/2/0/0	10.10.1.101	Up	Up
gi0/2/0/1	10.1.1.1	Up	Up
gi0/2/0/2	10.1.1.2	Up	Up
gi0/2/0/3	unassigned	Shutdown	Down
TenGigE0/3/0/0	unassigned	Shutdown	Down
TenGigE0/3/0/2	unassigned	Shutdown	Down
MgmtEth0/RSP0/CPU0/0	unassigned	Shutdown	Down

Step 8 Repeat these steps for every interface, until every interface shows both Status and Protocol as “Up.”

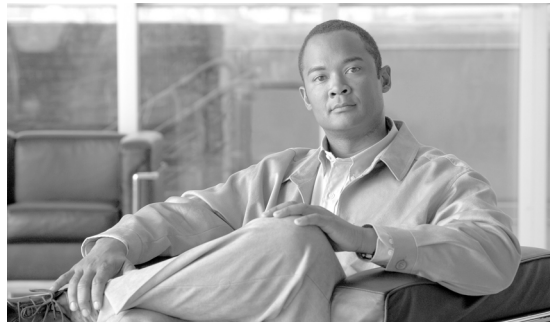

APPENDIX **A**

Understanding Regular Expressions, Special Characters, and Patterns

This appendix describes regular expressions, special or wildcard characters, and patterns used with filters to search through command output. Filter commands are described in the “[Filtering show Command Output](#)” section on page 5-9.

Contents

- [Regular Expressions, page A-1](#)
- [Special Characters, page A-2](#)
- [Character Pattern Ranges, page A-2](#)
- [Multiple-Character Patterns, page A-3](#)
- [Complex Regular Expressions Using Multipliers, page A-3](#)
- [Pattern Alternation, page A-4](#)
- [Anchor Characters, page A-4](#)
- [Underscore Wildcard, page A-4](#)
- [Parentheses Used for Pattern Recall, page A-4](#)

Regular Expressions

A regular expression is a pattern (a phrase, number, or more complex pattern).

- Regular expressions are case sensitive and allow for complex matching requirements. Simple regular expressions include entries like `Serial`, `misses`, or `138`.
- Complex regular expressions include entries like `00210...`, `(is)`, or `[Oo]utput`.

A regular expression can be a single-character pattern or multiple-character pattern. It can be a single character that matches the same single character in the command output or multiple characters that match the same multiple characters in the command output. The pattern in the command output is called a string.

The simplest regular expression is a single character that matches the same single character in the command output. Letter (A–Z and a–z), digits (0–9), and other keyboard characters (such as ! or ~) can be used as a single-character pattern.

Special Characters

Certain keyboard characters have special meaning when used in regular expressions. [Table A-1](#) lists the keyboard characters that have special meaning.

Table A-1 Characters with Special Meaning

Character	Special Meaning
.	Matches any single character, including white space.
*	Matches 0 or more sequences of the pattern.
+	Matches 1 or more sequences of the pattern.
?	Matches 0 or 1 occurrences of the pattern.
^	Matches the beginning of the string.
\$	Matches the end of the string.
_ (underscore)	Matches a comma (,), left brace ({), right brace (}), left parenthesis ((), right parenthesis ()), the beginning of the string, the end of the string, or a space.

To use these special characters as single-character patterns, remove the special meaning by preceding each character with a backslash (\). In the following examples, single-character patterns matching a dollar sign, an underscore, and a plus sign, respectively, are shown.

```
\$ \_ \+
```

Character Pattern Ranges

A range of single-character patterns can be used to match command output. To specify a range of single-character patterns, enclose the single-character patterns in square brackets ([]). Only one of these characters must exist in the string for pattern-matching to succeed. For example, **[aeiou]** matches any one of the five vowels of the lowercase alphabet, while **[abcdABCD]** matches any one of the first four letters of the lowercase or uppercase alphabet.

Simplify a range of characters by entering only the endpoints of the range separated by a dash (–), as in the following example:

```
[a–dA–D]
```

To add a dash as a single-character pattern in the search range, include another dash and precede it with a backslash:

```
[a–dA–D\–]
```

A bracket (]) can also be included as a single-character pattern in the range:

```
[a–dA–D\–\]]
```

Invert the matching of the range by including a caret (^) at the start of the range. The following example matches any letter except the ones listed:

```
[^a–dqsv]
```

The following example matches anything except a right square bracket (]) or the letter d:

```
[^\]d]
```

Multiple-Character Patterns

Multiple-character regular expressions can be formed by joining letters, digits, and keyboard characters that do not have a special meaning. With multiple-character patterns, order is important. The regular expression **a4%** matches the character **a** followed by a **4** followed by a **%**. If the string does not have **a4%**, in that order, pattern matching fails.

The multiple-character regular expression **a.** uses the special meaning of the period character to match the letter **a** followed by any single character. With this example, the strings **ab**, **a!**, and **a2** are all valid matches for the regular expression.

Put a backslash before the keyboard characters that have special meaning to indicate that the character should be interpreted literally. Remove the special meaning of the period character by putting a backslash in front of it. For example, when the expression **a\.** is used in the command syntax, only the string **a.** is matched.

A multiple-character regular expression containing all letters, all digits, all keyboard characters, or a combination of letters, digits, and other keyboard characters is a valid regular expression. For example: **telebit 3107 v32bis**.

Complex Regular Expressions Using Multipliers

Multipliers can be used to create more complex regular expressions that instruct Cisco IOS XR software to match multiple occurrences of a specified regular expression. [Table A-2](#) lists the special characters that specify “multiples” of a regular expression.

Table A-2 Special Characters Used as Multipliers

Character	Description
*	Matches 0 or more single-character or multiple-character patterns.
+	Matches 1 or more single-character or multiple-character patterns.
?	Matches 0 or 1 occurrences of a single-character or multiple-character pattern.

The following example matches any number of occurrences of the letter **a**, including none:

a*

The following pattern requires that at least one occurrence of the letter **a** in the string be matched:

a+

The following pattern matches the string **bb** or **bab**:

ba?b

The following string matches any number of asterisks (*):

To use multipliers with multiple-character patterns, enclose the pattern in parentheses. In the following example, the pattern matches any number of the multiple-character string **ab**:

(ab)*

As a more complex example, the following pattern matches one or more instances of alphanumeric pairs:

([A-Za-z][0-9])+

The order for matches using multipliers (*, +, and ?) is to put the longest construct first. Nested constructs are matched from outside to inside. Concatenated constructs are matched beginning at the left side of the construct. Thus, the regular expression matches A9b3, but not 9Ab3 because the letters are specified before the numbers.

Pattern Alternation

Alternation can be used to specify alternative patterns to match against a string. Separate the alternative patterns with a vertical bar (|). Only one of the alternatives can match the string. For example, the regular expression **codex|telebit** matches the string codex or the string telebit, but not both codex and telebit.

Anchor Characters

Anchoring can be used to match a regular expression pattern against the beginning or end of the string. Regular expressions can be anchored to a portion of the string using the special characters shown in [Table A-3](#).

Table A-3 Special Characters Used for Anchoring

Character	Description
^	Matches the beginning of the string.
\$	Matches the end of the string.

For example, the regular expression **^con** matches any string that starts with con, and **sole\$** matches any string that ends with sole.

In addition to indicating the beginning of a string, the ^ can be used to indicate the logical function “not” when used in a bracketed range. For example, the expression **[^abcd]** indicates a range that matches any single letter, as long as it is not the letters a, b, c, and d.

Underscore Wildcard

Use the underscore to match the beginning of a string (^), the end of a string (\$), parentheses (()), space (), braces ({}), comma (,), and underscore (_). The underscore can be used to specify that a pattern exists anywhere in the string. For example, **_1300_** matches any string that has 1300 somewhere in the string and is preceded by or followed by a space, brace, comma, or underscore. Although **_1300_** matches the regular expression **{1300_}**, it does not match the regular expressions **21300** and **1300t**.

The underscore can replace long regular expression lists. For example, instead of specifying **^1300() ()1300\$ {1300, ,1300, {1300} ,1300, (1300,** simply specify **_1300_**.

Parentheses Used for Pattern Recall

Use parentheses with multiple-character regular expressions to multiply the occurrence of a pattern. IOS XR can remember a pattern for use elsewhere in the regular expression.

To create a regular expression that recalls a previous pattern, use parentheses to indicate memory of a specific pattern and a backslash (\) followed by a digit to reuse the remembered pattern. The digit specifies the occurrence of a parenthesis in the regular expression pattern. When there is more than one remembered pattern in the regular expression, \1 indicates the first remembered pattern, \2 indicates the second remembered pattern, and so on.

The following regular expression uses parentheses for recall:

a(.)bc(.)\1\2

This regular expression matches an a followed by any character (call it character number 1), followed by bc followed by any character (character number 2), followed by character number 1 again, followed by character number 2 again. So, the regular expression can match aZbcTZT. The software remembers that character number 1 is Z and character number 2 is T, and then uses Z and T again later in the regular expression.

